

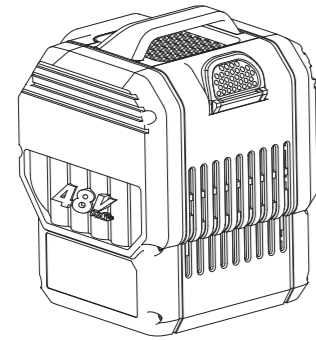

YARDWORKS®/MD

48V Max* Lithium-ion Battery

model number ABP4850SH | contact us: 1.866.523.5218



IMPORTANT:

Read and follow all safety rules and operating instructions before using this product.

Instruction Manual

2

model number ABP4850SH | contact us:

Table of Contents

Product Specifications	2
Safety Instructions and Symbols	3
Product Diagram	6
Operation	7
Troubleshooting	11
Warranty	12
Environmentally Safe Battery Disposal	13

Product Specifications

PRODUCT SPECIFICATIONS

Item number	ABP4850SH
Battery voltage	48V $\overline{---}$
Battery capacity	5.0 Ah
Battery Weight	4.58 lbs (2.08 kg)
Battery type	Lithium-ion

Battery only for use with chargers: 060-1990-2/060-1992-8

3

model number ABP4850SH | contact us: 1.866.523.5218

Safety Instructions

Save all warnings and instructions for future reference. Use battery pack for YARDWORKS® cordless products only. Refer to the marking label and instruction manual provided with product.

Safety Warnings for Battery Pack

- Do not dismantle, open or shred battery pack.
- Do not expose battery pack to heat or fire. Avoid storage in direct sunlight.
- Do not short-circuit a battery pack. Do not store battery packs haphazardly in a box or drawer where they may short-circuit each other or be short-circuited by other metal objects. When battery pack is not in use, keep it away from other metal objects, like paper clips, coins, keys, nails, screws or other small metal objects, that can make a connection from one terminal to another. Shorting the battery terminals together may cause burns or fire.
- Do not remove battery pack from its original packaging until required for use.
- Do not subject battery pack to mechanical shock.
- In the event of battery leaking, do not allow the liquid to come in contact with the skin or eyes. If contact has been made, wash the affected area with copious amounts of water and seek medical advice.
- Observe the plus (+) and minus (-) marks on the battery pack and equipment and ensure correct use.
- Do not use any battery pack which is not designed for use with the equipment.
- Keep battery pack out of the reach of children.
- Seek medical advice immediately if a cell or battery has been swallowed.
- Always purchase the battery pack recommended by the manufacturer for the equipment.
- Keep battery pack clean and dry.
- Wipe the battery pack terminals with a clean dry cloth if they become dirty.
- Battery pack needs to be charged before use. Always use the correct charger and refer to the manufacturer's instructions or equipment manual for proper charging instructions.
- Do not leave battery pack on prolonged charge when not in use.
- After extended periods of storage, it may be necessary to charge and discharge the battery pack several times to obtain maximum performance.
- Battery pack gives its best performance when it is operated at normal room temperature 20°C ± 5 °C (68°F ± 9°F).
- When disposing of battery packs, keep battery packs of different electrochemical systems separate from each other.
- Recharge only with the charger specified by YARDWORKS®. Do not use any charger other than that specifically provided for use with the equipment. A charger that is suitable for one type of battery pack may create a risk of fire

4

model number ABP4850SH | contact us: 1.866.523.5218

Safety Instructions

- when used with another battery pack.
- Retain the original product literature for future reference.
- Use only the battery pack in the application for which it was intended.
- Remove the battery pack from the equipment when not in use.
- Dispose of property.

WARNING: Read all safety warnings and instructions. Failure to follow the warnings and instructions may result in electric shock, fire and/or serious injury.

5

model number ABP4850SH | contact us: 1.866.523.5218

Some of the following symbols may be used on this product. Please study them and learn their meaning. Proper interpretation of these symbols will allow you to operate the product effectively and safely.

Symbol	Designation/Explanation
	To reduce the risk of injury, user must read instruction manual.
	Lithium-ion battery; battery must be recycled.
	Do not burn.
	Batteries may enter water cycle if disposed improperly, which can be hazardous for ecosystem. Do not dispose of waste batteries as unsorted municipal waste.

call 2 recycle

Yardworks® Canada has established a partnership with the RBRC Corporation to recycle any Yardworks® batteries with the RBRC-call 2 recycle seal. For environmental protection, please do not discard batteries in the trash. After the battery's life cycle has ended, please call 1-800-822-8837 for a free service to properly dispose of the battery.

6

model number ABP4850SH | contact us: 1.866.523.5218

Product Diagram

- Carry Handle
- Battery Release Button

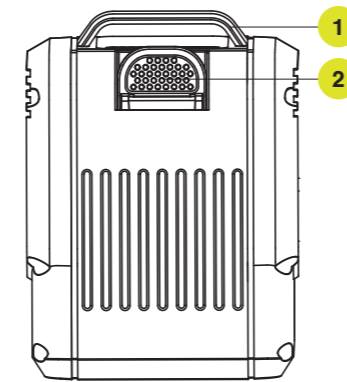

WARNING: Remove the battery pack from the package and examine it carefully. Do not discard the carton or any packaging material until all parts have been examined.

WARNING: If any part of the battery pack is missing or damaged, do not attach the battery pack to the tool until the part has been repaired or replaced. Failure to heed this warning could result in serious injury.

7

model number ABP4850SH | contact us: 1.866.523.5218

Operation

NOTE: Before using your battery pack, be sure to read the instruction manual carefully.

Before attempting to use this tool, become familiar with all of its operating features and safety requirements. For optimum performance and safety, read the following operating instructions carefully before using.

WARNING: Do not allow familiarity with the battery to cause a lack of alertness. A fraction of a second of carelessness is enough to cause severe injury. Do not continue to press the On/Off switch after the machine has automatically switched off. The battery could be over-discharged.

NOTE:

- Your battery pack is UNCHARGED. To ensure full capacity of the battery, completely charge the battery in the battery charger before using your power tool for the first time.
- A battery pack will slowly lose its charge when kept out of the charger or left in an unplugged charger for a long time. It may need to be recharged before use.
- Charge the lithium-ion battery pack only with the correct charger.

The Li-ion battery is protected against deep discharging. When the battery is empty, the machine is switched off by means of a protective circuit: the tool no longer operates. In a warm environment or after heavy use, the battery pack may become too hot to permit charging. Allow time for the battery to cool down before recharging. The Li-ion battery can be charged at any time without reducing its service life. Interrupting the charging procedure does not damage the battery.

COLD WEATHER OPERATION

When the battery pack is very cold, it may "pulse" for the first minute of use in order to warm itself. Put the battery pack on a tool and use the tool in a light application. After about a minute, the battery pack will have warmed itself and will operate normally.

8

model number ABP4850SH | contact us: 1.866.523.5218

Operation

How to charge the battery pack (See Fig. A1, A2)

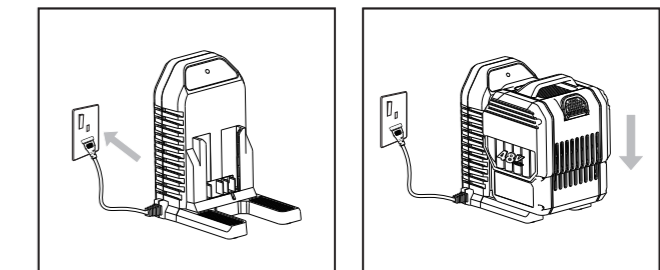

A1

A2

CHARGING PROCEDURE

- Plug the charger into an appropriate outlet.
- Slide the battery pack into the charger, make sure the battery is in the correct charge position firmly. The light will begin flashing green to indicate the charging process has started.
- When charging is completed, the light will turn solid green.
- After the battery is fully charged, unplug the charger and remove the battery pack.

TRANSPORT

The contained Li-ion batteries are subject to the dangerous goods legislation requirements. The user can transport the batteries by road without additional requirements. Dispatch batteries only when the battery housing is undamaged. Pack up the batteries in such a manner that they cannot move around in the packaging.

Made in China
Imported by Yardworks Canada Toronto, Canada M4S 2B8

YARDWORKS®/MD

model number ABP4850SH | contact us: 1.866.523.5218

model number ABP4850SH | contact us: 1.866.523.5218

model number ABP4850SH | contact us: 1.866.523.5218

model number ABP4850SH | contact us: 1.866.523.5218

MAINTENANCE

Occasionally clean the venting slots of the battery using a soft, clean and dry brush. It is good practice to unplug the charger and remove the lithium-ion battery pack when not in use. A significantly reduced working period after fully charging indicates that the battery is at the end of its working life and must be replaced.



WARNING: To avoid serious personal injury, always remove the battery pack from the tool when cleaning or performing any maintenance.



WARNING: Do not at any time let brake fluids, gasoline, petroleum-based products, penetrating oils, etc., come in contact with plastic parts. Chemicals can damage, weaken or destroy plastic which may result in serious personal injury.



WARNING: To reduce the risk of fire, personal injury, and product damage due to a short circuit, never immerse your tool, battery pack or charger in fluid or allow a fluid to flow inside them. Corrosive or conductive fluids, such as seawater, certain industrial chemicals, and bleach or bleach containing products, etc., can cause a short circuit.

STORAGE

Store the battery between -10 and 55°C (14 and 131°F). Do not leave the battery in the car in summer. It is recommended that the battery be stored indoors for the winter months.

For lithium-ion battery pack storage longer than 30 days:

- Store the lithium-ion battery pack where the temperature is below 40°C(104°F) and free of moisture.
- Every six months of storage, fully charge the lithium-ion battery pack.
- Exterior may be cleaned with a cloth or soft, non-metallic brush.

The following table gives checks and actions that you can perform if your battery does not operate correctly. If these do not identify/remedy the problem, contact Yardworks® at 1.866.523.5218.

Symptom	Possible Causes	Solution
The battery pack does not work	The battery pack charge has run out.	Charge the battery pack.
The battery cannot be correctly charged in the charger (Indicator light is red)	Flashing Red: the battery pack is too hot or too cold. Constantly Red: the battery pack is defective.	Allow the battery pack to reach normal temperature and re-charge the battery pack. Take the defective battery pack to the local service centre.

This Yardworks product carries a three (3) year warranty against defects in workmanship and materials.

Should this Yardworks product become defective within the stated warranty period, return it to the store with proof of purchase, and it will be replaced or repaired free of charge.

Made in China. Imported by Yardworks Canada
Toronto, Canada M4S 2B8

model number ABP4850SH | contact us: 1.866.523.5218

ENVIRONMENTALLY SAFE BATTERY DISPOSAL

The batteries used in this battery pack contain the following toxic and corrosive material: LITHIUM-ION.



Follow these instructions to avoid damage to the environment:

- Cover the battery's terminals with heavy-duty adhesive tape.
- Do not attempt to remove or destroy any of the components of the battery pack.
- Do not attempt to open the battery pack.
- If a leak develops, the electrolytes that are released are corrosive and toxic. Do not get the solution in the eyes or on the skin, and do not swallow it.
- Do not place batteries in regular household trash.
- DO NOT incinerate batteries.
- DO NOT place batteries where they will become part of any waste landfill or municipal solid waste stream.
- Dispose of batteries at a certified recycling or disposal centre.



WARNING: Toxic materials must be disposed of in a specific manner in order to prevent contamination of the environment. Before disposing of damaged or worn out lithium-ion battery packs, contact your local waste disposal agency or the local Canadian Environmental Protection Agency for information and specific instructions. Take the batteries to a local recycling and/or disposal centre that is certified for disposal. If the battery pack cracks or breaks, whether it leaks or not, do not recharge it and do not use it. Dispose of it and replace it with a new battery pack. DO NOT ATTEMPT TO REPAIR IT!