

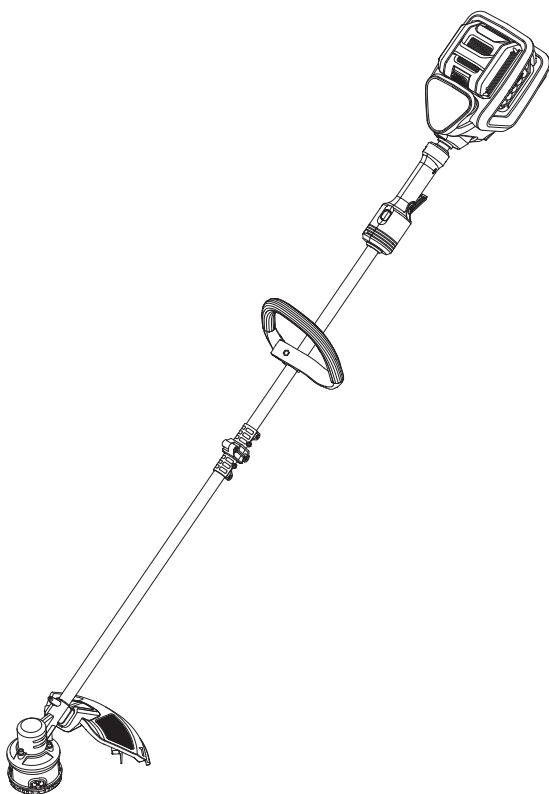

YARDWORKS^{®/MD}

36 cm (14") BRUSHLESS GRASS TRIMMER

model no. 060-1963-8 | contact us 1.866.523.5218



IMPORTANT:

Read and follow all safety rules and operating instructions before using this product.

**Instruction
Manual**



For problems or questions, **DO NOT RETURN TO STORE**. Please contact one of our Customer Service Agents who will be happy to assist you.

For customer assistance please call:



CANADA: 1.866.523.5218

Introduction	4
Safety Instructions	5
Symbols	8
Product Specifications	9
Product Diagram	10
Assembly	11
Operation	13
Maintenance and Storage	18
Troubleshooting	19
Exploded View	20
Parts List	21
Warranty	22



Please do not operate garden equipment near children. This could lead to severe injury or death.

INTRODUCTION

Congratulations on your purchase of your new Yardworks® tool. It has been designed, engineered and manufactured to give you the best possible dependability and performance.

Should you experience any problem you cannot easily remedy, please contact our Yardworks® customer service line at 1.866.523.5218.

PLEASE READ AND RETAIN THIS INSTRUCTION MANUAL. These instructions will enable you to assemble and maintain your appliance properly. **ALWAYS** observe the “SAFETY RULES”.

The instruction manual was designed to conveniently help you get your purchase ready to use so there's less risk of damage and to provide you with enough information to get familiar with your product's controls and features so you can operate your product safely.

SAFETY FIRST



CAUTION: The operation of lawn equipment can result in foreign objects thrown into the eyes, which can result in SEVERE EYE INJURY. ALWAYS wear safety glasses or eye shields while operating your lawn equipment or performing any adjustments or repairs. We recommend standard safety glasses or a wide vision safety mask worn over spectacles.



Please read this manual carefully and make sure you understand the instructions before using the machine.

Model number: _____

Serial number: _____

Date of purchase (MM/DD/YYYY): _____

Notes: _____

FOR ALL APPLIANCES

- Avoid dangerous environments — do not use appliances in damp or wet locations.
- Don't use in rain.
- Keep children away — all people and pets should be kept at a distance from the work area.
- Dress properly — do not wear loose clothing or jewellery. They can be caught in moving parts. Wear protective clothing; use of work gloves, long pants, a long-sleeved shirt and safety footwear is recommended when working outdoors. Wear protective hair covering to contain long hair.
- Use safety glasses — always use face or dust mask if the area in which you are working is dusty.
- Use the right appliance — do not use appliance for any job except that for which it is intended.
- Do not force appliance — it will do the job better and with less likelihood of a risk of injury at the rate for which it was designed.
- Do not overreach — keep proper footing and balance at all times.
- Stay alert. Use common sense. Do not operate appliance when you are tired or under the influence of drugs, alcohol or medication.
- When not in use, appliances should be stored indoors in dry places out of reach of children.
- Maintain appliance with care. Follow instructions for lubricating and changing accessories. Keep handles dry, clean, and free from oil and grease.
- Check damaged parts. Before using the appliance, make sure the safety guards are intact. Never use a tool without its

safety guard. Check the alignment of the moving parts, the binding of the moving parts. Check for broken or defective parts that can affect the safe operation of your tool. A guard or other part that is damaged should be properly repaired or replaced by an authorized service centre unless indicated elsewhere in this manual.

FOR ALL BATTERY-OPERATED GARDENING APPLIANCES:

1. Prevent unintentional starting. Ensure the switch is in the off-position before connecting to battery pack, picking up or carrying the appliance. Carrying the appliance with your finger on the switch or energizing an appliance that has the switch on invites accidents.
2. Disconnect the battery pack from the appliance before making any adjustments, changing accessories, or storing appliance. Such preventive safety measures reduce the risk of starting the appliance accidentally.
3. Recharge only with the charger specified by the manufacturer. A charger that is suitable for one type of battery pack may create a risk of fire when used with another battery pack.
4. Use appliances only with specifically designated battery packs. Use of any other battery packs may create a risk of injury and fire.
5. When battery pack is not in use, keep it away from other metal objects, like paper clips, coins, keys, nails, screws or other small metal objects, that can make a connection from one terminal to another. Shorting the battery terminals together may cause burns or a fire.
6. Under abusive conditions, liquid may be ejected from the battery; avoid contact.

**Important Safety Instructions**

WARNING: Read all safety warnings and instructions. Failure to follow the warnings and instructions may result in electric shock, fire and/or serious injury.

If contact accidentally occurs, flush with water. If liquid contacts eyes, additionally seek medical help. Liquid ejected from the battery may cause irritation or burns.

7. Do not use a battery pack or appliance that is damaged or modified. Damaged or modified batteries may exhibit unpredictable behaviour resulting in fire, explosion or risk of injury.
8. Do not expose a battery pack or appliance to fire or excessive temperature. Exposure to fire or temperature above 130°C (265°F) may cause an explosion.
9. Follow all charging instructions and do not charge the battery pack or appliance outside of the temperature range specified in the instructions. Charging improperly or at temperatures outside of the specified range may damage the battery and increase the risk of fire.
10. Have servicing performed by a qualified repair person using only identical replacement parts. This will ensure that the safety of the product is maintained.
11. Do not modify or attempt to repair the appliance or the battery pack (as applicable) except as indicated in the instructions for use and care.

FOR LAWN TRIMMER AND EDGE TRIMMER

1. Keep guards in place and in good working order.
2. Keep hands and feet away from cutting area.
3. Do not use heavier lines than recommended in this manual.
4. Do not use line materials of other types – for example, metal wire, rope, and the like.

FOR BATTERY PACK

1. Do not dismantle, open or shred cells or battery pack.
2. Do not expose battery pack to heat or fire. Avoid storage in direct sunlight.

3. Do not short-circuit a battery pack. Do not store battery packs haphazardly in a box or drawer where they may short-circuit each other or be short-circuited by conductive materials. When battery pack is not in use, keep it away from other metal objects, like paper clips, coins, keys, nails, screws or other small metal objects, that can make a connection from one terminal to another. Shorting the battery terminals together may cause burns or a fire.
4. Do not subject battery pack to mechanical shock.
5. In the event of battery leaking, do not allow the liquid to come into contact with the skin or eyes. If contact has been made, wash the affected area with copious amounts of water and seek medical advice.
6. Do not use any battery pack which is not designed for use with the equipment.
7. Keep battery pack out of the reach of children.
8. Always purchase the battery pack recommended by the device manufacturer for the equipment.
9. Keep battery pack clean and dry.
10. Wipe the battery pack terminals with a clean, dry cloth if they become dirty.
11. Battery pack needs to be charged before use. Always use the correct charger and refer to the manufacturer's instructions or equipment manual for proper charging instructions.
12. Do not leave battery pack on prolonged charge when not in use.
13. After extended periods of storage, it may be necessary to charge and discharge the battery pack several times to obtain maximum performance.
14. Recharge only with the charger specified by Yardworks®. Do not use any charger other than that specifically provided for use with the equipment.
15. Retain the original product literature for future reference.

model no. 060-1963-8 | contact us 1.866.523.5218

16. Use only the battery pack in the application for which it was intended.
17. Remove the battery from the equipment when not in use.
18. Dispose of properly.
19. Do not mix cells of different manufacture, capacity, size or type within a device.
20. Keep the battery away from microwaves and high pressure.

Information for radiated emission

This device complies with Canadian ICES-001.

This device complies with Part 15 of the FCC Rules.

Operation is subject to the following two conditions:

- (1) This device may not cause harmful interference; and
- (2) This device must accept any interference received, including interference that may cause undesired operation.

NOTE: This equipment has been tested and found to comply with the limits for a Class B digital device, pursuant to Part 15 of the FCC Rules.

These limits are designed to provide reasonable protection against harmful interference in a residential installation. This equipment generates, uses and can radiate radio frequency energy and, if not installed and used in accordance with the instructions, may cause harmful interference to radio communications.

However, there is no guarantee that interference will not occur in a particular installation. If this equipment does cause harmful interference to radio or television









reception, which can be determined by turning the equipment off and on, the user is encouraged to try to correct the interference by one or more of the following measures:

- Reorient or relocate the receiving antenna.
- Increase the separation between the equipment and receiver.
- Connect the equipment into an outlet on a circuit different from that to which the receiver is connected.
- Consult the dealer or an experienced radio/TV technician for help.





WARNING: Changes or modifications to this unit not expressly approved by the party responsible for compliance could void the user's authority to operate the equipment.

Some of the following symbols may be used on this product. Please study them and learn their meaning. Proper interpretation of these symbols will allow you to operate the product effectively and safely.

Symbol	Designation/Explanation
	To reduce the risk of injury, user must read instruction manual.
	Warning
	Wear eye protection
	Wear ear protection
	This part directs thrown objects away from the operator
 Li-ion	Li-ion battery; battery must be recycled.
	Do not burn.
	Batteries may enter water cycle if disposed improperly, which can be hazardous for ecosystem. Do not dispose of waste batteries as unsorted municipal waste.
	Yardworks® Inc. has established a partnership with the RBRC Corporation to recycle any Yardworks® batteries with the RBRC-call2recycle seal. For environmental protection, please do not discard batteries in the trash. After the battery's life cycle is ended, please call 1-800-822-8837 for a free service that will properly dispose of the battery.

model no. 060-1963-8 | contact us 1.866.523.5218







TECHNICAL DATA

Voltage	48V 
No Load Speed	0-6000 RPM
Cutting Diameter	36 cm (14")
Line Diameter	2.0 mm (0.080")
Line Length	4 m (160")
Battery Capacity (060-1987-2)	2.0 Ah
Charger Input (060-1990-2)	120 V~, 60 Hz, 110 W
Charger Output (060-1990-2)	48 V  , 2 A
Charging Time	1 hr
Machine Weight	11 lb 7 oz (5.2 kg)

SUITABLE BATTERY PACKS

Item Number	060-1987-2	ABP4830SH1	060-1988-0	ABP4850SH	060-1989-8
Battery Capacity	2.0 Ah	3.0 Ah	4.0 Ah	5.0 Ah	6.0 Ah
	Included	Not included	Not included	Not included	Not recommended

SUITABLE CHARGERS

Item Number	060-1990-2	060-1992-8	060-1909-0
Charger Input	120 V~, 60 Hz, 110 W	120 V~, 60 Hz, 320 W	120 V~, 60 Hz, 250 W
Charger Output	48 V  , 2 A	48 V  , 6 A	48 V  , 2 A (output 1) 48 V  , 2 A (output 2)
Charger Protection Class	 /II	 /II	 /II
	Included	Not included	Not included

model no. 060-1963-8 | contact us 1.866.523.5218

1. Battery pack (060-1987-2)
2. Battery pack release button
3. Hex key
4. On/Off switch with variable speed control
5. Lock-off button
6. Auxiliary handle
7. Handle locking nut
8. Handle locking clamp
9. Handle locking knob
10. Upper shaft
11. Couplings
12. Lower shaft
13. Safety guard
14. Trimmer head
15. Spool holder
16. Line cutter
17. Spool holder release knob x 2
18. Bump knob
19. Line fitting knob
20. Line
21. Line fitting hole x 2
22. Charger (060-1990-2)
23. Bolt x 3 (Fig. A2 & C1)

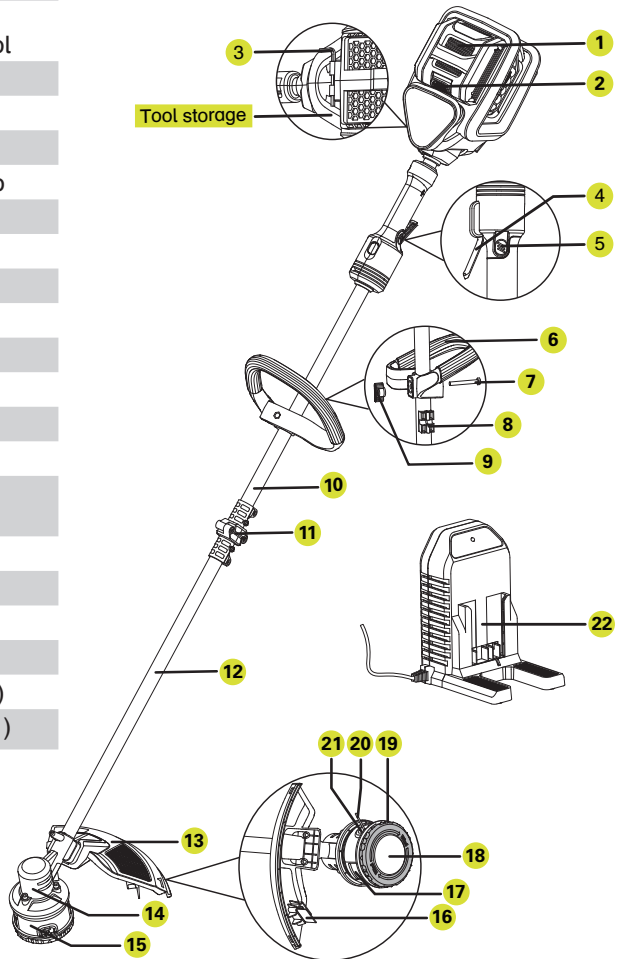

WARNING: Any other accessory or attachment may increase the risk of injury.



To reduce the risk of injury, user must read instruction manual.

Intended Use

The machine is intended for the cutting of grass and weeds under bushes as well as on slopes and edges that cannot be reached with a lawn mower.

1. ASSEMBLING THE UPPER SHAFT AND LOWER SHAFT

Connect the couplings into each other (see Fig. A1). Align the holes and fasten the couplings by screwing the bolt with the hex key (see Fig. A2).

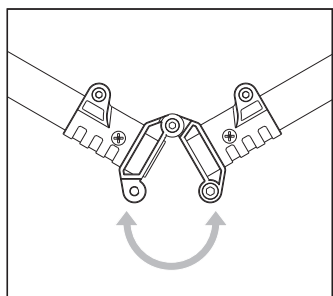

A1

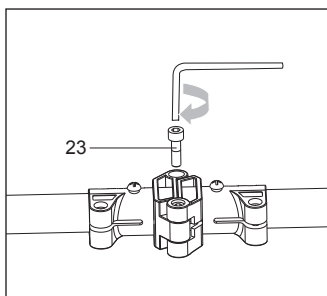

A2

2. ASSEMBLING THE AUXILIARY HANDLE

Attach the auxiliary handle and locking clamp on the upper shaft (see Fig. B1). Put the locking nut through the holes and tighten the auxiliary handle with the locking knob (see Fig. B2).

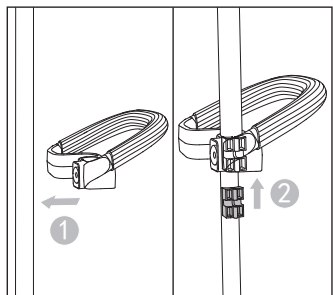

B1

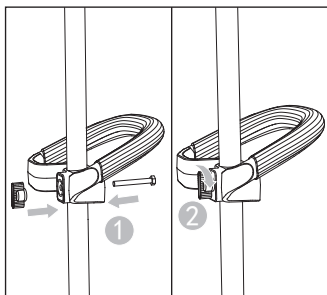

B2



CAUTION! The trimmer must not be operated before it has been assembled completely.



CAUTION! Do not insert the battery until the trimmer has been completely assembled.

3. ASSEMBLING THE SAFETY GUARD

Attach the safety guard to the lower shaft as shown in Fig. C1. Align the 2 holes on the safety guard with the 2 corresponding holes on the lower shaft.

Hold the safety guard in place and insert the 2 bolts into the 2 aligned holes.

Secure the safety guard onto the lower shaft with the provided hex key (see Fig. C2).

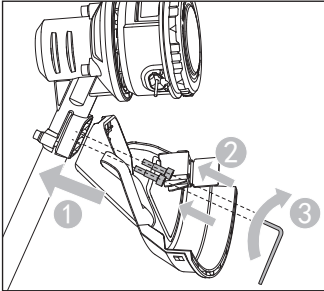

C1

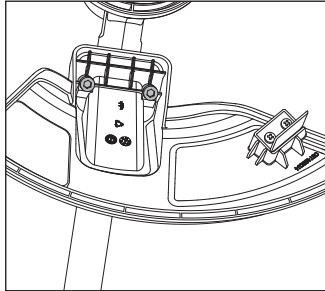

C2



WARNING: The guard has a very sharp line cutter.



WARNING: Never operate the tool without the guard properly in place. Use of the unit without having installed the guard may result in injury.

model no. 060-1963-8 | contact us 1.866.523.5218

BEFORE USING YOUR LINE TRIMMER

1. CHARGING THE BATTERY (SEE FIG. D)

- The battery in your new tool is not charged when it leaves the plant; therefore, it must be fully charged before using the first time.
- If the battery pack is very hot, remove the battery from the charger and allow it to cool to ambient temperature before attempting to recharge.
- To prevent damage to the battery pack, please charge the battery to full or no less than half charge before storage.
- If the tool will not be used for long periods of time, charge the battery pack every 3 – 6 months.

- CHARGING PROCEDURE

- Plug the charger into an appropriate outlet.
- Slide the battery pack into the charger; make sure the battery is in the correct charge position firmly. The charger light will begin flashing green to indicate the charging process has started.
- When charging is completed, the light will turn solid green.
- When the battery is fully charged, unplug the charger and remove the battery pack.

NOTE: If the battery pack is locked in the charger, press the battery pack release button and remove it.

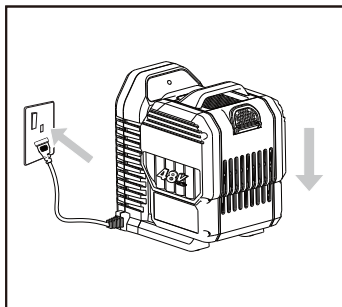

D











WARNING! The charger and battery pack are specially designed to work together, so do not attempt to use any other devices. Never insert or allow metallic objects into your charger or battery pack connections because an electrical failure and hazard will occur.



WARNING: When battery charge runs out after continuous use or exposure to direct sunlight or heat, allow time for the battery to cool down before re-charging to achieve the full charge.

- CHARGING INDICATOR

This charger is designed to detect some problems that can arise with battery packs. Indicator lights indicate problems (see table below).

Light	ON/ Flash	Status
Red on ●  	————	Defective battery.
Red flash  	Battery Temperature Protection. The temperature of battery pack is less than 0°C (32°F) or more than 40°C (104°F).
Green on ●  	————	Fully charged.
Green flash  	Charging.

2. INSTALLING AND REMOVING THE BATTERY PACK

Slide the battery pack into tool's battery port. A simple push and slight pressure will be sufficient (see Fig. E1).

Press the battery pack latch and remove the battery pack from the tool (see Fig. E2).

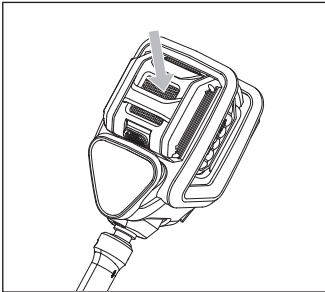

E1

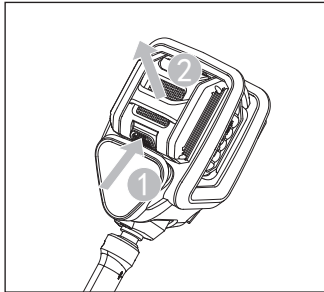

E2

model no. 060-1963-8 | contact us 1.866.523.5218

OPERATION

1. ON/OFF SWITCH WITH VARIABLE SPEED CONTROL

To switch on, press the lock-off button first, then the On/Off switch (see Fig. F). To switch off, release the On/Off switch.

The On/Off switch is also a variable speed switch that delivers higher speed with increased trigger pressure. Speed is controlled by the amount of switch trigger depression.

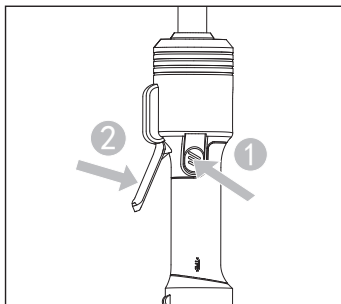

F

2. TRIMMING

- 1) Keep the trimmer head at an angle of about 30° to the ground when trimming (see Fig. G1).
- 2) Do not cut wet grass because the grass tends to stick to the trimmer head and guard, prevents proper discharge of grass clippings, and could cause you to slip and fall.
- 3) Regularly remove clippings and dirt around the trimmer head. Ensure the trimmer is switched off.
- 4) Work rhythmically, and stand firmly with your feet apart. Cut from right to left so the trimmings will be thrown away from the work area (see Fig. G2).
- 5) When cutting long or high grass, please make sure that you cut the grass down in 2 to 3 stages (see Fig. G3, G4).
- 6) Do not move the trimmer too fast as this will result in ineffective cutting and possible damage.



WARNING: Always wear eye protection. Never lean over the trimmer head. Rocks or debris can ricochet or be thrown into eyes and face and cause blindness or other serious injury.



WARNING: Make sure that line is fed out before operation. Make sure motor is up to full speed before trimming.



WARNING: Do not remove or alter the line-cutting blade assembly. Excessive line length will be cut to suitable length.

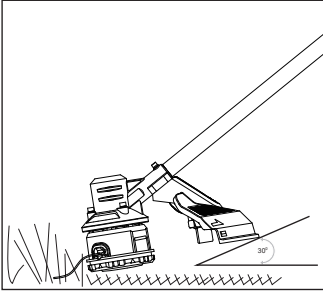

G1

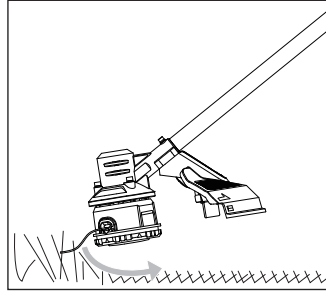

G2

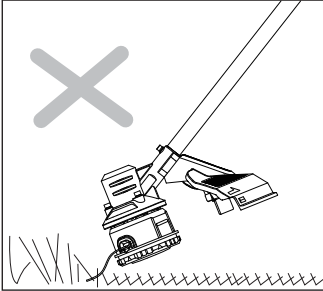

G3

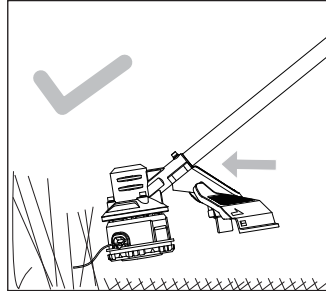

G4

3. ADJUSTING CUTTING LINE LENGTH

The trimmer head allows the operator to release more cutting line without stopping the motor. As line becomes frayed or worn, additional line can be released by lightly tapping the bump knob on the ground while operating the trimmer (see Fig. H).

NOTE: Line release will become more difficult if the line cutter becomes dull.

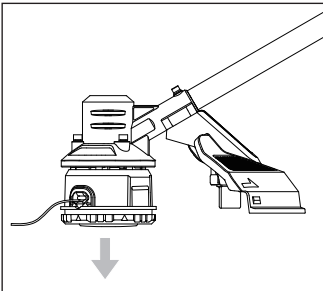

H

3. REPLACING THE LINE

With the automatic line fitting system, you only need to replace the line instead of replacing the whole spool holder, and you do not need to wind the line manually.

- 1) Remove the battery pack from the grass trimmer first.
 - 2) Cut a piece of line approximately 4 m (160").
 - 3) Turn over the grass trimmer. Insert one end of the line continuously into a line fitting hole at the edge side of the spool holder, and the line will go through the inner spool holder itself and stretch out from the other line fitting hole (see Fig. I1).
 - 4) Pull out the other end of the line until half of the line is stretched out from the other hole. Note that the length of the two parts line should be the same (see Fig. I2).
 - 5) Hold the spool holder by hand and grip the line fitting knob with another hand, rotate the line fitting knob clockwise (the same direction shown on the bump knob). The line will wind onto the spool automatically (see Fig. I3).
 - 6) Continue to rotate the line fitting knob until the line is at the desired length (see Fig. I4).
- NOTE:** Do not over-rotate the line fitting knob, or the extended line will be too short.

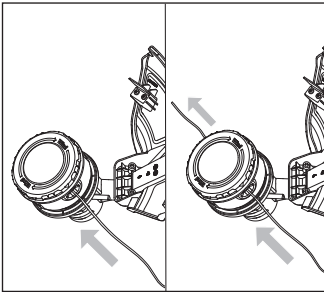

I1

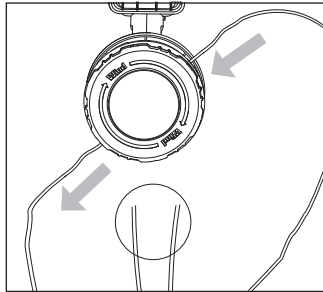

I2

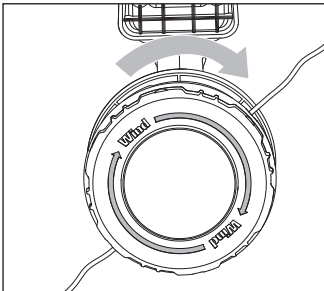

I3

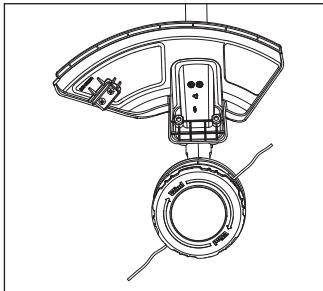

I4



WARNING: Your trimmer is designed to use only line with a maximum diameter of 2.0 mm (0.080").



WARNING: Always remove the battery pack from your trimmer after use.

MAINTENANCE

Always check the product prior to use for any damage.

After use, disconnect the battery from the tool and check for damage.

Your power tool requires no additional lubrication or maintenance. There are no user serviceable parts in your power tool. Never use water or chemical cleaners to clean your power tool. Wipe clean with a dry cloth. Always store your trimmer in a dry room. Keep the motor ventilation slots clean. Keep all working controls free of dust.

STORAGE

Store in a dry place where the trimmer and battery can be protected from damage.

For battery tools

The ambient temperature range for the use and storage of tool and battery is 0 to 45°C (32 to 113°F).

The recommended ambient temperature range for the charging system during charging is 0 to 40°C (32 to 104°F).

It is recommended that the battery be stored indoors for the winter months.

TROUBLESHOOTING

The following table gives problems and actions that you can perform if your machine does not operate correctly. Warning: Switch the trimmer off and remove the battery prior to any troubleshooting.

Problem	Possible Cause	Corrective Action
Trimmer fails to operate.	Battery discharged.	Recharge battery; also see the content in charger manual.
	Battery too hot/cold.	Allow to cool/warm.
	Motor is broken. Internal wiring of machine damaged.	Contact Yardworks [®] at 1.866.523.5218. Contact Yardworks [®] at 1.866.523.5218.
Trimmer runs intermittently.	Motor is broken.	Contact Service Agent.
	Battery not fully charged. On/Off switch defective.	Recharge battery. Contact Yardworks [®] at 1.866.523.5218.
Excessive vibrations /noise.	Machine defective.	Contact Yardworks [®] at 1.866.523.5218.
	Line spool is not wound well.	Rewind the line. See "Replacing the line".
Cutting time per battery charge too short.	Battery has not been used for long period or only charged for short term.	Fully charge battery; also see the content in charger manual.
	Grass too high.	Cut in stages.
	Battery defective.	Replace the battery.
Machine does not cut.	Line broken.	Replace the line.
	Battery not fully charged.	Recharge battery; also see the content in charger manual.
	Motor is broken (speed is too low). Grass entangled around cutting head.	Contact Yardworks [®] at 1.866.523.5218. Remove grass.
Continuous lighting of the battery charge indicator/ battery not charging.	Battery not (properly) inserted.	Properly insert battery into battery charger.
	Battery contacts contaminated.	Clean the battery contacts or replace the battery.
	Battery defective.	Replace the battery.
Battery charge indicator does not light up.	Plug of battery charger not plugged in (properly).	Insert mains plug (fully) into the socket outlet.
	Outlet or mains cable defective.	Check the mains voltage.
	Battery charger defective.	Replace the battery charger.

Exploded View

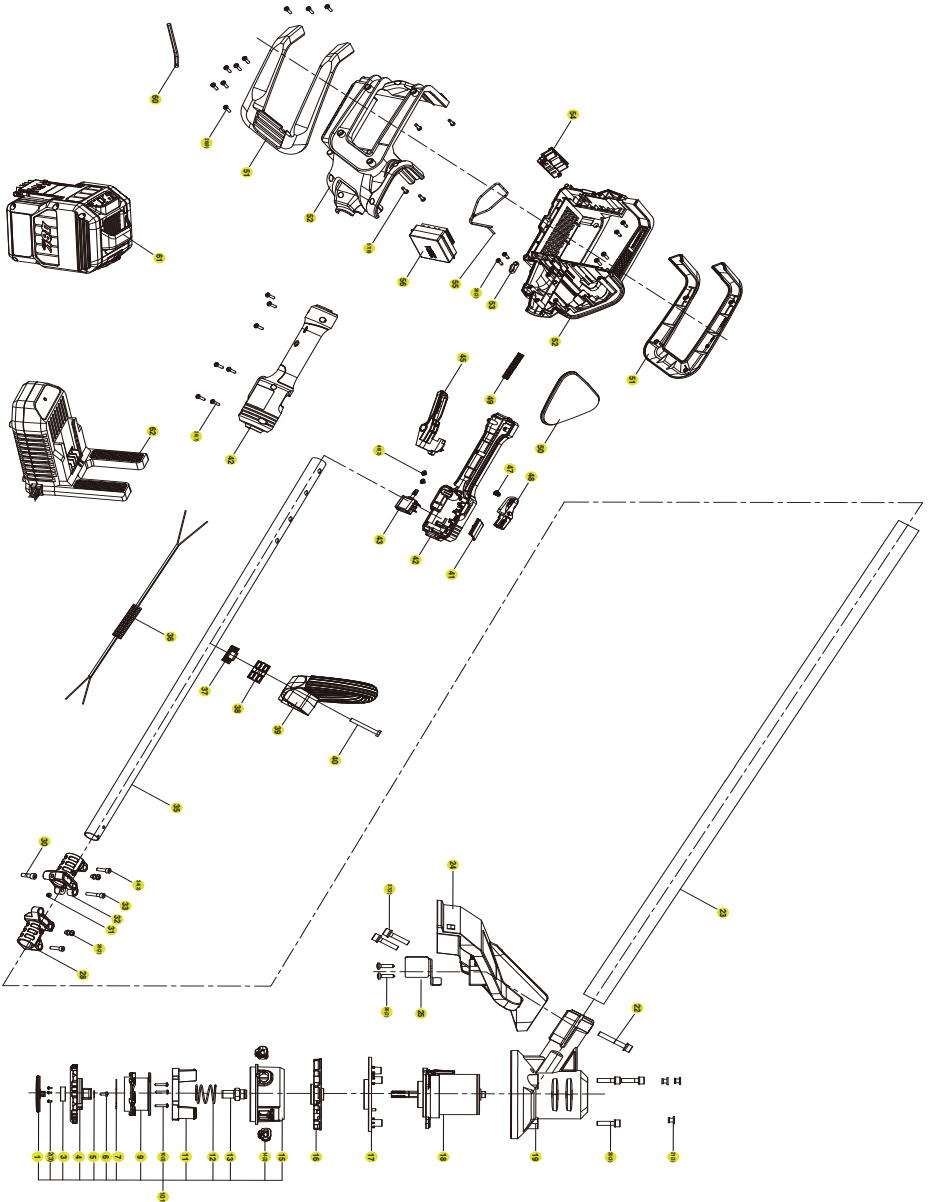

model no. 060-1963-8 | contact us 1.866.523.5218

No.	Part Description	Quantity			
1	Cover	1	37	Angle Knob	1
2	Self Tapping Screw	3	38	Press Plate	1
3	Ball Bearing 6000	1	39	Auxiliary Handle	1
4	Cutting Head Cover	1	40	Bolt	1
5	Washer	1	41	Handle Cover	1
6	Self Tapping Screw	1	42	Left/Right Handle	1
7	Separate Plate	1	43	Switch	1
9	Spool & Line	1	45	Trigger	1
10	Self Tapping Screw	3	46	Self Tapping Screw	2
11	Inner Cover	1	47	Compression Spring	1
12	Compression Spring	1	48	Lock Knob	1
13	Output Shaft	1	49	Tube	1
14	Rivet	2	50	Decorative Cover	1
15	Chuck Body	1	51	Left/Right Side Cover	1
16	Fan	1	52	Left/Right Battery Support	1
17	Motor Mounting Plate	1	53	Cord Clamp	1
18	Motor	1	54	Terminal	1
19	Housing	1	55	Torsional Spring	1
20	Screw	3	56	Protect Control Board	1
21	Rubber Sleeve	3	57	Self Tapping Screw	8
22	Screw Washer Assembly	1	60	Spanner	1
23	Lower Aluminium Tube	1	61	Battery Pack (060-1987-2)	1
24	Guard Set	1	62	Charger (060-1990-2)	1
25	Blade	1	101	Cutting Head Assembly	1
26	Self Tapping Screw	20			
27	Screw	2			
28	Connector II	1			
29	Screw Washer Assembly	2			
30	Screw	1			
31	Nut	1			
32	Connector I	1			
33	Screw	1			
34	Screw	2			
35	Upper Aluminium Tube	1			
36	Connection Wire	1			

FIVE-YEAR LIMITED WARRANTY

For five (5) years from the date of purchase within Canada, Yardworks Canada will, at its option, repair or replace for the original purchaser, free of charge, any part or parts found to be defective in material or workmanship (excludes battery and charger).

For three (3) years from the date of purchase within Canada, Yardworks Canada will, at its option, repair or replace for the original purchaser, free of charge, any battery or charger found to be defective in material or workmanship.

THIS WARRANTY DOES NOT COVER

1. Any part that has become inoperative due to misuse, commercial use, abuse, neglect, accident, improper maintenance, or alteration;
2. The unit, if it has not been operated and/or maintained in accordance with the owner's manual;
3. Normal wear, except as noted below;
4. Routine maintenance items such as lubricants, blade sharpening; or
5. Normal deterioration of the exterior finish due to use or exposure.

FULL ONE YEAR (365) DAYS WARRANTY ON NORMAL WEAR PARTS

Normal wear parts are defined as blade adaptors, blades, grass bags and tires. These parts are warranted to the original purchaser to be free from defects in material and workmanship for a period of three hundred and sixty-five (365) days from the date of retail purchase.

HOW TO OBTAIN SERVICE

Warranty service is available by calling the toll-free helpline at 1.866.523.5218. The factory will not accept the return of a complete unit unless prior written permission has been extended by Yardworks Canada.

TRANSPORTATION CHARGES

Transportation charges for the movement of any power equipment unit or attachment are the responsibility of the purchaser. The purchaser must pay transportation charges for any part submitted for replacement under this warranty unless such return is requested in writing by Yardworks Canada.

OTHER WARRANTIES

All other warranties, express or implied, including any implied warranty of merchantability is limited in its duration to that set forth in this express limited warranty. The provisions as set forth in this warranty provide the sole and exclusive remedy of Yardworks Canada obligations arising from the sale of its products.



Always remove or disconnect the battery pack before adjusting, cleaning, servicing or transporting your appliance.



model no. 060-1963-8 | contact us 1.866.523.5218

FCC Part 15

Supplier's Declaration of Conformity
Product Description: 48V 2.0A Charger
Model Number: 060-1990-2
Trade Name: YARDWORKS®

This device complies with part 15 of the FCC Rules.
Operation is subject to the following two conditions:
(1) This device may not cause harmful interference, and
(2) This device must accept any interference received, including interference that may cause undesired operation.

Responsible Party:



YARDWORKS™

1.866.523.5218

Made in China
Imported by Yardworks Canada
Toronto, Canada M4S 2B8

