

model no. 060-1552-6

MASTERCRAFTTM

CORDLESS BRUSHLESS 2-IN-1 LAWN MOWER

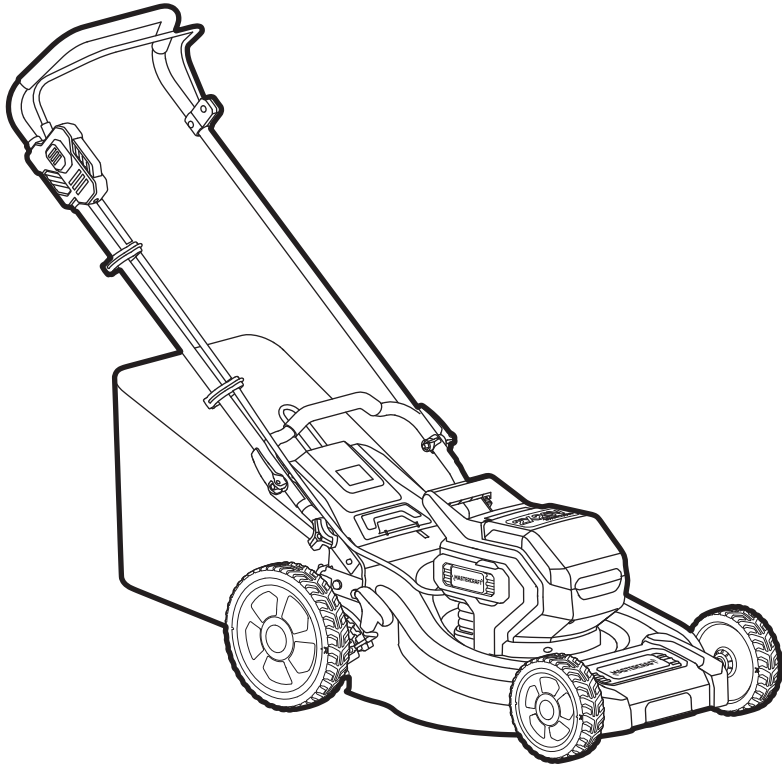

IMPORTANT :

Read and understand this instruction manual thoroughly before using the product.

**INSTRUCTION
MANUAL**

TABLE OF CONTENTS

Technical Specifications	4
Safety Guidelines	5
Key Parts Diagram	10
Operating Instructions	11
Maintenance	15
Troubleshooting	17
Parts List	18
Warranty	21

NOTE:

If any parts are missing or damaged, or if you have any questions, please call our toll-free helpline at 1-800-689-9928.



SAVE THESE INSTRUCTIONS

- This manual contains important safety and operating instructions. Read all instructions and follow them when using this product.

TECHNICAL SPECIFICATIONS

Rated Voltage	40 V d.c.
Deck Size	19" (48 cm)
Cutting Height	1 1/2 to 3" (3.8 to 7.6 cm)

*Maximum battery voltage without workload; with workload nominal voltage is 18 V.

Recommend using tool with Mastercraft® 20V max* Lithium-Ion 4.0 Ah battery (054-7557-6; sold separately) for optimal performance.

NOTICE: The mower needs two 20 V max* batteries to work.

SAFETY GUIDELINES:



WARNING!

Safety symbols in this Instruction Manual are used to flag possible dangers. The safety symbols and their explanations require your full understanding. The safety warnings do not, by themselves, eliminate any danger, nor are they substitutes for proper accident prevention measures.

IMPORTANT

This tool should only be serviced by a qualified service technician. For more information, call the toll-free helpline at 1-800-689-9928. This machine is capable of amputating hands and feet and throwing objects. Failure to observe the following safety instructions could result in serious injury or death.



WARNING!

When using electric lawn mowers, basic safety precautions should always be followed to reduce the risk of fire, electric shock, and personal injury, including the following.

READ ALL INSTRUCTIONS

GENERAL INFORMATION

- Read, understand, and follow instructions and warnings in this manual and on the machine and attachments.
- Only allow operators who are responsible, trained, familiar with the instructions, and physically capable to operate the machine.
- Do not operate the machine while under the influence of alcohol or drugs.

PREPARATION BEFORE OPERATING

- Clear the operation area of any objects which could be thrown by or interfere with operation of the machine.
- Keep the area of operation clear of all bystanders, particularly small children. Stop the machine and attachment(s) if anyone enters the area.
- Do not operate the machine without the entire grass catcher, discharge chute, or other safety devices in place and functioning properly. Check frequently for signs of wear or deterioration and replace as needed.
- Wear appropriate personal protective equipment such as safety glasses, hearing protection, and footwear.

CHILDREN SPECIFIC

- Tragic accidents can occur if the operator is not alert to the presence of children. Children are often attracted to the machine and mowing activity. Never assume that children will remain where you last saw them.

- Keep children out of the operating area and under the watchful care of a responsible adult other than the operator.

OPERATING

- **Only operate the machine in daylight or good artificial light.**
- **Avoid holes, nuts, bumps, rocks, or other hidden hazards.** Uneven terrain could overturn the machine, or cause operator to lose the balance or footing.
- **Do not put hands or feet near rotating parts of under the machine.** Keep clear of the discharge opening at all times.
- **Do not direct discharge material toward anyone.** Avoid discharging material against a wall or obstruction. Material may ricochet back toward the operator. Stop the blade(s) when crossing gravel surface.
- **Do not mow in reverse unless absolutely necessary.** Always look down and behind before and when backing up.
- **Avoid dangerous environment.** Don't use lawn mowers in damp or wet locations.
- **Don't use in rain.**
- **Keep children away.** All visitors should be kept a safe distance from work area.
- **Dress properly.** Do not wear loose clothing or jewellery. They can be caught in moving parts. Use of rubber gloves and footwear is recommended when working outdoors.
- **Use safety glasses.** Always use face or dust mask if operation is dusty.
- **Use right appliance.** Do not use lawn mower for any job except that for which it is intended.
- **Don't force lawn mower.** It will do the job better and safer at the rate for which it was designed.
- **Don't overreach.** Keep proper footing and balance at all times.
- **Stay alert.** Watch what you are doing. Use common sense. Do not operate lawn mower when you are tired.
- **Store idle lawn mower indoors.** When not in use, lawn mower should be stored in an indoor, dry and locked-up place out of reach of children.
- **Maintain lawn mower with care.** Keep cutting edges sharp and clean for best and safest performance. Follow instructions for lubricating and changing accessories. Inspect lawn mower cord periodically and if damaged, have it repaired by an authorized service facility. Keep handles dry, clean, and free from oil and grease.
- **Keep guards in place and in working order.**
- **Keep blades sharp.**
- **Keep hands and feet away from cutting area.**
- **Objects struck by the lawn mower blade can cause severe injuries to persons.** The lawn should always be carefully examined and cleared of all objects prior to each mowing.

- If lawn mower strikes a foreign object, follow these steps: 1) Stop lawn mower; release the switch. 2) Unplug power cord. 3) Inspect for damage. 4) Repair any damage before restarting and operating the lawn mower.
- **Use identical replacement blades only.**
- **Use extra care while operating machine with grass catcher or other attachment(s).** They can affect the stability of the machine.

SAFETY GUIDELINES FOR BATTERY-OPERATED TOOLS

- **Prevent unintentional starting.** Ensure the switch is in the off-position before connecting to battery pack, picking up or carrying the appliance. Carrying the appliance with your finger on the switch or energizing appliance that have the switch on invites accidents.
- **Disconnect the battery pack from the appliance before making any adjustments, changing accessories, or storing appliance.** Such preventive safety measures reduce the risk of starting the appliance accidentally.
- **Recharge only with the charger specified by the manufacturer.** A charger that is suitable for one type of battery pack may create a risk of fire when used with another battery pack.
- **Use appliances only with specifically designated battery packs.** Use of any other battery packs may create a risk of injury and fire.
- **When battery pack is not in use, keep it away from other metal objects, like paper clips, coins, keys, nails, screws or other small metal objects, that can make a connection from one terminal to another.** Shorting the battery terminals together may cause burns or a fire.
- **Under abusive conditions, liquid may be ejected from the battery; avoid contact. If contact accidentally occurs, flush with water.** If liquid contacts eyes, seek additional medical help. Liquid ejected from the battery may cause irritation or burns.
- **Do not use a battery pack or appliance that is damaged or modified.** Damaged or modified batteries may exhibit unpredictable behaviour resulting in fire, explosion or risk of injury.
- **Do not expose a battery pack or appliance to fire or excessive temperature.** Exposure to fire or temperature above 130°C (265°F) may cause an explosion.
- **Follow all charging instructions and do not charge the battery pack or appliance outside of the temperature range specified in the instructions.** Charging improperly or at temperatures outside of the specified range may damage the battery and increase the risk of fire.
- **Have servicing performed by a qualified repair person using only identical replacement parts.** This will ensure that the safety of the product is maintained.
- **Do not modify or attempt to repair the appliance or the battery pack (as applicable) except as indicated in the instructions for use and care.**

OPERATION ON A SLOPE

Slopes are a major factor related to slip-and-fall accidents, which can result in severe injury. Operation on slopes requires extra caution. If you feel uneasy on a slope, do not mow it.

- Mow across the face of slopes; never mow up and down. Exercise extreme caution when changing direction on slopes.
- Watch for holes, ruts, rocks, hidden objects, or bumps which can cause you to slip or trip. Tall grass can hide obstacles.
- Do not mow near drop-offs, ditches or embankments; you could lose your footing or balance.
- Do not mow slopes greater than 15 degrees. Do not mow on wet grass. Unstable footing could cause slipping.
- Do not operate machine under any condition where traction, steering, or stability is in question. Tires could slide even if the wheels are stopped.
- Always keep the machine in gear when going down slopes. Do not coast downhill.
- Avoid starting and stopping on slopes. Avoid making sudden changes in speed or direction. Make turns slowly and gradually.

ADDITIONAL SAFETY GUIDELINES FOR LAWN MOWER

- **The label on your tool may include the following symbols. The symbols and their definitions are as follows:**

V Volts

A Amperes

W Watts

min Minutes

 or d.c. Direct current

n_0 No-load speed

 Class II construction

RPM Revolutions per minute

 WARNING—To reduce the risk of injury, user must read instruction manual.

 WARNING—To reduce the risk of injury, always wear eye protection.

 WARNING—To reduce the risk of injury, always wear ear protection.

 ... Maintain safety devices: Do not open or remove safety shields while the tool is running.

 Look behind when backing up. Look down and behind first to avoid tripping when pulling back.

 DANGER—Keep hands and feet away. To reduce the risk of injury, keep hands and feet away from rotating parts. Do not operate unless discharge cover or grass bag is in its proper place. If damaged, replace immediately.

 DANGER—Keep bystanders away. Do not mow when children or others are around.



..... DANGER—Thrown debris. Remove objects that can be thrown by the blade in any direction. Wear safety glasses.



..... DANGER—Steep slope hazard. Use extra caution on slopes. Do not mow slopes greater than 15 degrees.



WARNING!

To reduce the risk of electric shock or damage to the charger and battery, use only the Mastercraft® battery and chargers listed.

BATTERY PACK

CHARGERS

054-7557-6, 054-7553-4, 054-3124-0

054-3126-6, 054-7559-2

- **For best results, your battery and tool should be stored, charged and used in a location where the temperature is more than 5°C (41°F) but less than 40°C (104°F).** Do not store outside or in vehicles.
- **Do not wash the mower with a hose.** Avoid getting water in the motor and electrical connections.
- **To reduce a fire hazard, keep the motor cover free of grass, leaves and debris build-up.**

SAVE THESE INSTRUCTIONS!

PACKAGE CONTENTS:

Cordless lawn mower, (2) cable clamps, grass collection bag, (2) bolts, (2) knobs, (2) locking levers, (2) washers, (2) nuts, upper handle bar, lower handle bar, mulching insert (inside of the mower).

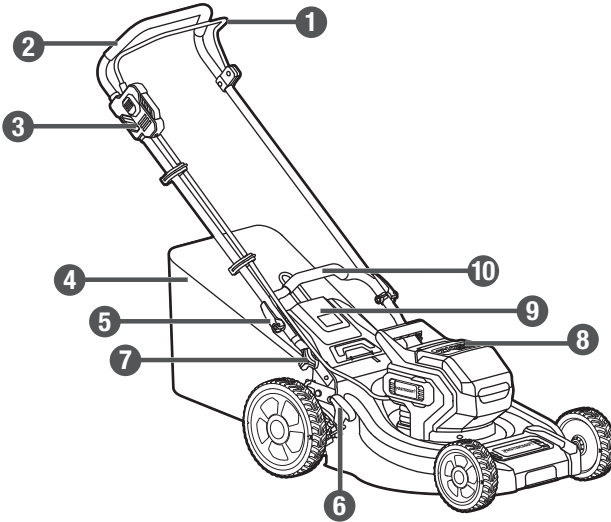
KEY PARTS DIAGRAM

No.	Description
1	Start lever
2	Upper handle bar
3	Safety lock-off switch
4	Grass collection bag
5	Locking lever

No.	Description
6	Cutting-height-adjustment lever
7	Knob
8	Battery compartment
9	Rear-discharge door
10	Lower handle bar

Before attempting to use this tool, become familiar with all of its operating features and safety requirements. For optimum performance and safety, read the following operating instructions carefully before using.

**WARNING!**

- Remove the lawn mower from the package and examine it carefully. Do not discard the carton or any packaging material until all parts have been examined.
- If any part of the lawn mower is missing or damaged, do not attach the battery pack to the tool or use the tool until the part has been repaired or replaced. Failure to heed this warning could result in serious injury.
- Do not allow familiarity with the lawn mower to cause a lack of alertness. A fraction of a second of carelessness is enough to cause severe injury.

OPERATING INSTRUCTIONS

ASSEMBLE THE LOWER HANDLE BAR

1. Align one hole of the lower handle bar with the rib on the mower, attach the lower handle bar onto the rib, and then align the other side of the lower handle bar to attach the bar onto the other rib (**fig 1a**). It's recommended to use a flat-head screwdriver to assemble the lower handle bar.
2. Make the raised foam portion of the lower handle bar face upwards, otherwise you will have less space to attach or remove the grass collection bag (**fig 1b**). The insert picture shows the outline when looking at the back of the lower handle bar.
3. Insert the bolts into the square holes as shown in **fig 1c** and then turn the knobs clockwise to lock the lower handle bar onto the mower.

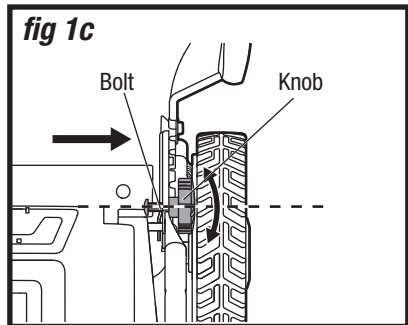
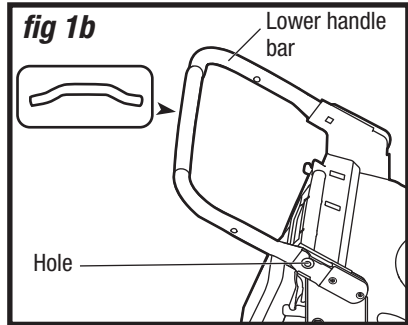
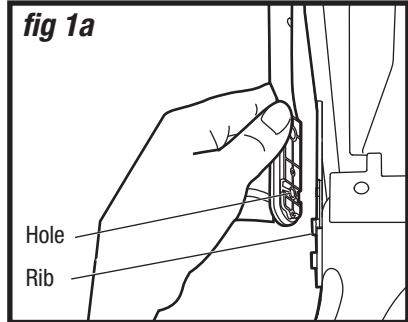

NOTICE:

- The bolt with the square head should be fully inserted into the square hole on the mower.
- If you couldn't fully tighten the upper handle bar, you should further turn the locking levers clockwise.

ASSEMBLE THE UPPER HANDLE BAR (fig 2)

1. Align the holes on the upper handle bar with the holes on the lower handle bar.
2. Insert the locking levers with washers into the holes and nuts and then turn the locking levers clockwise to lock the upper handle bar onto the lower handle bar.

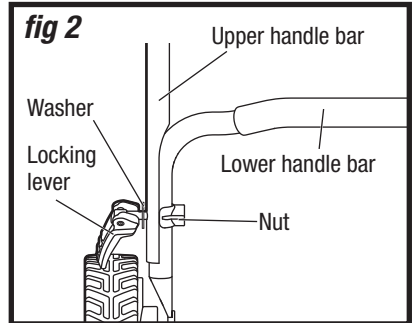

CABLE CLAMP (fig 3)

This mower is equipped with two cable clamps. Simply press the cable clamps onto the bar, and then the cable can be fixed onto the upper handle bar.

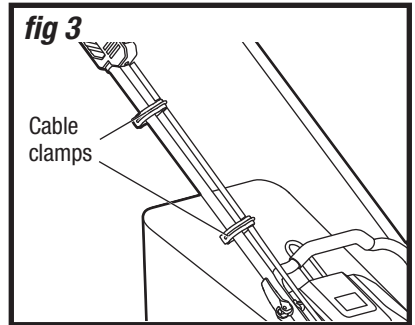

ATTACH/REMOVE THE MULCHING INSERT (fig 4)

1. Lift the rear-discharge door and insert the mulching insert into the grass outlet of the mower. And then release the rear-discharge door.
2. To remove it, lift the rear-discharge door and just pull the mulching insert out directly. Then release the rear-discharge door.

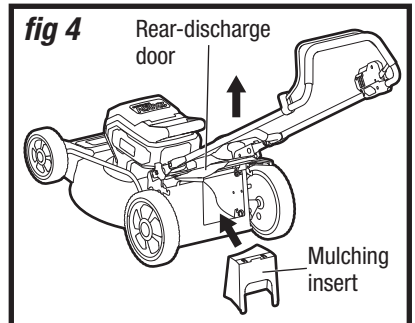

NOTICE:

- The mulching insert must be removed in order to install and use the grass collection bag.
- When using the function of the mulching insert, you can get more fine grass clippings on your lawn.
- Empty the grass collection bag frequently during use. Do not wait until it is completely full. We recommend emptying it when it is half full.

ATTACH/REMOVE THE GRASS COLLECTION BAG (fig 5)

1. Remove the pre-installed mulching insert before attaching the grass collection bag to the mower.
2. Use one hand to lift the rear-discharge door; use your other hand to hold the handle bar of the grass collection bag, and align the rods on the grass collection bag with the slots on the mower to assemble it.
3. To remove the grass collection bag, just lift the rear-discharge door and remove the rods of grass collection bag.

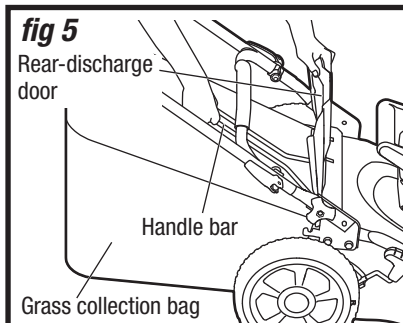

ADJUST THE CUTTING HEIGHT (fig 6)

Pull out the cutting-height-adjustment lever from the slot, then move it forward or backward to adjust the cutting height (**fig 6a**). The mower has five slots which can adjust the cutting height from about 1 1/2 to 3" (3.8 to 7.6 cm). Do not place the lever out of the five slots (**fig 6b**).

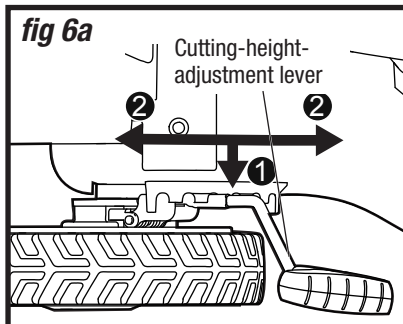

TO ATTACH THE BATTERY (fig 7)

1. Open the protective cap of the battery compartment.
2. Align the raised portion on the battery pack with the grooves inside of the battery compartment, and then slide the battery pack onto the mower.
3. Ensure that the battery-release button on the battery pack snaps into place and the battery pack is secured to the tool before beginning operation.

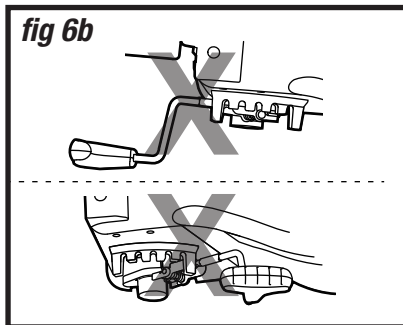

NOTICE: Two batteries should be used together to start the mower. The mower cannot be used with only one battery.



WARNING!

- Keep your feet away from the deck when adjusting its height.
- To avoid the possibility of accidental starting, always take care not to activate the start lever when you are attaching the battery pack or performing other adjustments to the tool.

TO DETACH THE BATTERY (fig 7)

1. Open the protective cap of the battery compartment.
2. Depress the battery-release button located on the front of the battery pack to release the battery.
3. Pull rearward on the battery pack to remove it from the tool.

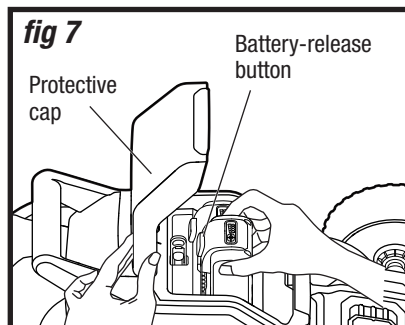
**SAFETY KEY (fig 8)**

In order to prevent accidental start-up or unauthorized use of your cordless mower, a removable safety key has been incorporated into the design of your mower.

The mower will be completely disabled when the safety key has been removed from the mower. Press the lever, insert the safety key into the assembly slot, and then the mower may be operated.

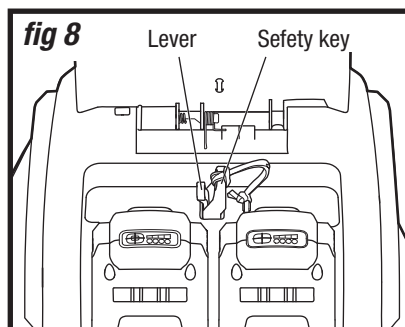
**START/STOP THE MOWER (fig 9)**

1. Install the battery packs into the mower, insert the safety key into the key slot and then close the battery compartment.
2. Depress the safety lock-off switch first, pull back the start lever to meet the handle and then release the safety lock-off switch to start the machine.
3. To stop, fully release the start lever. The electric brake will stop the blade rotation within several seconds after releasing the start lever.

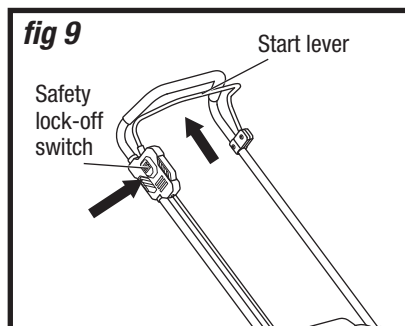
**WARNING!**

- Rotating blades can cause serious injury. To prevent serious injury, remove the safety key when the mower is unattended, or when adjusting, cleaning, servicing, transporting, lifting, or storing the mower.
- The operation of any lawn mower can result in foreign objects being thrown into your or others' eyes, which can damage eyes severely. Always wear safety glasses while operating the mower or while performing any adjustments or repairs on the mower.
- Ensure that other people and pets remain at least 100' (30 m) away from the mower when it is in use.
- The blade will continue to rotate for a few seconds after the mower is turned off. Allow the motor/blade to stop rotating before starting it again. Do not rapidly turn the mower off and on.

MAINTENANCE

REMOVE/INSTALL THE BLADE (fig 10)

After prolonged use, especially in sandy soil conditions, the blade will become worn and lose some of the original shape, which will reduce the cutting efficiency. Therefore, the blade should be replaced to ensure a good cutting performance.

1. Remove the safety key and battery pack.
2. Turn the mower upside down. Keep the underbody and blade clean and free of debris.
3. Use a piece of wood to keep the blade from turning, loosen the hex bolt counter-clockwise using a suitable wrench and remove it together with the blade.
4. Attach a new blade of the same type onto the spindle while maintaining the correct alignment. Insert the hex bolt on the spindle. Use a piece of wood to keep the blade from turning, and then tighten the hex bolt clockwise to ensure safe operation of your product.

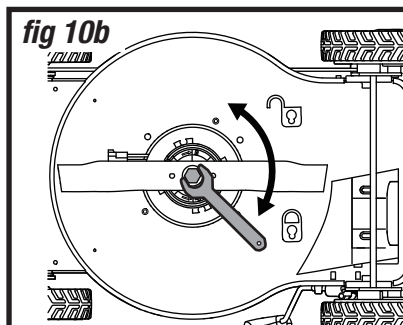
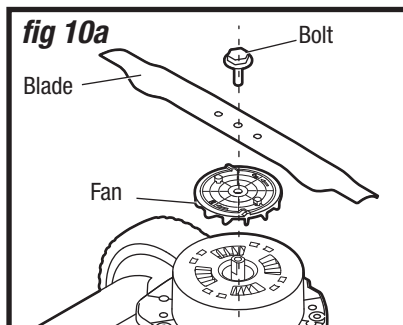

CLEAN THE MOWER

The underside of mower deck should be cleaned after each use as grass clippings, leaves, dirt and other debris will accumulate. This accumulation is undesirable, and it will promote rust and corrosion on metal parts and reduce the cutting efficiency of the mower. Wipe the mower clean with a damp cloth.

STORAGE (fig 11)

1. Switch the product off and remove the safety key and battery packs.
2. Store the product and its accessories in a dark, dry, frost-free, and well-ventilated place.
3. Always store the product in a place that is inaccessible to children.
4. Do not store it next to corrosive materials, such as fertilizer or rock salt.
5. The mower can be stored in a compact way. Pull out and press locking levers (**fig 11a**) to the position as shown in **fig 11b**, and then you can fold the upper handle bar into the storage position (**fig 11c**).

To unfold and use the mower, simply lift the locking lever to the locked position as shown in **fig 11a**.

CARRY THE MOWER (fig 11c)

After folding the mower, it can be carried using the lower handle and the handle on the battery compartment together, as shown in **fig 11c**. DO NOT attempt to lift the mower by grasping the upper handle bar.

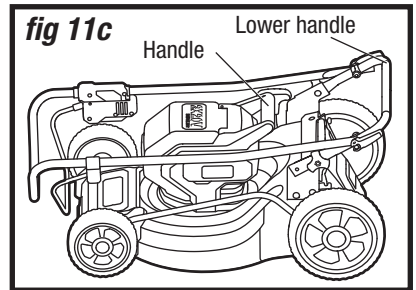
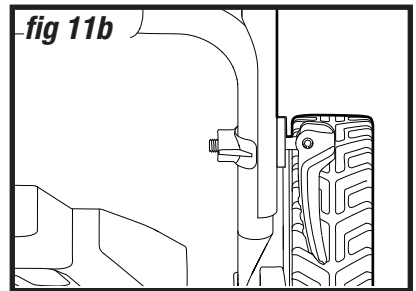
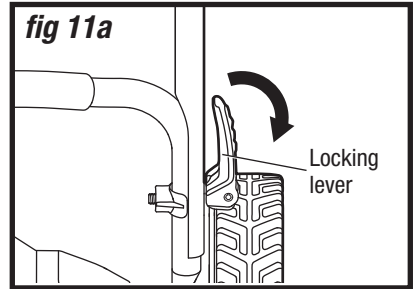
**WARNING!**

- Wear safety gloves when working on the blade and close to it. Use proper tools to remove debris, i.e., a wooden stick. Never use your bare hands.
- Do not let brake fluids, gasoline, petroleum-based products, penetrating oil, etc., come into contact with plastic parts. These substances contain chemicals that can damage, weaken, or destroy plastic.
- When servicing, use only identical replacement parts. The use of any other parts may create a hazard or cause damage to the product.
- Always remove the safety key and battery pack when servicing or transporting the mower.
- To ensure safety and reliability, all repairs should be performed by a qualified service technician.

TROUBLESHOOTING

Problem	Possible causes	Solutions
The mower doesn't work.	The battery is depleted.	Charge the battery pack.
	The motor or the battery is over-loaded.	Raise the cutting height, and restart the tool again.
	The battery or the tool is too hot.	Wait for the battery or tool to cool down, and then start the tool again.
	The safety key is not inserted into the slot of the battery compartment.	Insert the safety key into the slot.
Mower runs but cutting performance is unsatisfactory.	Blade is dull.	Keep the blade sharp.
	Deck or discharge chute is clogging.	Clean the deck or discharge chute.
Mower is abnormally noisy and vibrates.	The blade is bent or damaged.	Replace with a new blade.
Grass collection bag doesn't pick up grass clippings.	Discharge chute is clogged.	Clear the grass clippings in the discharge chute.
	Bag is full.	Empty the bag more often.

If the problem remains unsolved after performing the checks described above, call the toll-free helpline at 1-800-689-9928.

EXPLODED VIEW

PARTS LIST

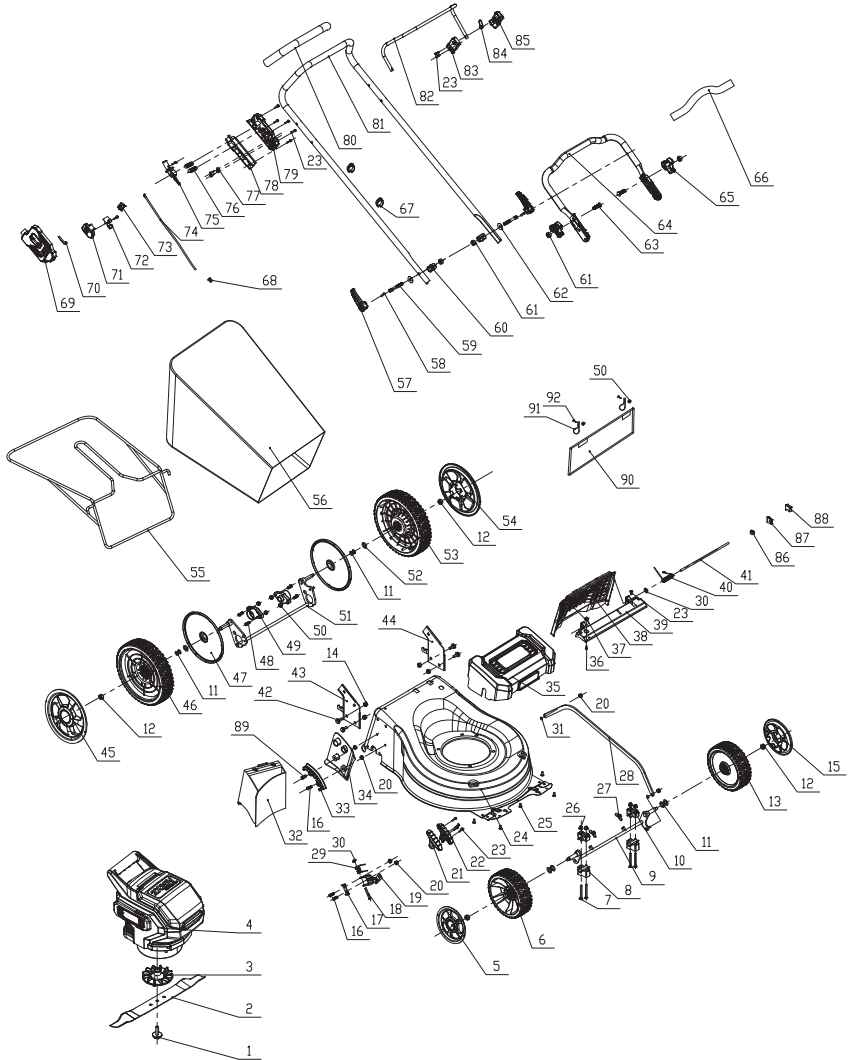

No.	Part no.	Description
1	0601350601	Blade Bolt
2	0601350602	Blade
3	0601350603	Fan
4	0601350604	Power Head
5	0601350605	Right Front Wheel Cover
6	0601350606	Right Front Wheel
7	0601350607	Square Head Bolt
8	0601350608	Front Wheel Bracket
9	0601350609	Front Wheel Axle
10	0601350610	Front Wheel Bracket
11	0601350611	Wave Washer
12	0601350612	Hexagonal Nut
13	0601350613	Left Front Wheel
14	0601350614	Flange Nut
15	0601350615	Left Front Wheel Cover
16	0601350616	Screw
17	0601350617	Torsion Spring Seat
18	0601350618	Shaft
19	0601350619	Assembly
20	0601350620	Hexagonal Nut
21	0601350621	Right Height Handle
22	0601350622	Left Height Handle
23	0601350623	Screw
24	0601350624	Base
25	0601350625	Screw
26	0601350626	Nut
27	0601350627	Tension Spring
28	0601350628	Connecting Rod
29	0601350629	Torsion Spring
30	0601350630	E-Ring Circlip
31	0601350631	Flat Washer
32	0601350632	Mulching Insert

No.	Part no.	Description
33	0601350633	Plate
34	0601350634	Grass Guide Plate
35	0601350635	Front Face
36	0601350636	Square Head Bolt
37	0601350637	Hexagonal Nut
38	0601350638	Back Cover
39	0601350639	Dust Strip
40	0601350640	Torsion Spring
41	0601350641	Pin
42	0601350642	Bolt
43	0601350643	Bracket
44	0601350644	Bracket
45	0601350645	Right Rear Wheel Cover
46	0601350646	Right Wheel
47	0601350647	Rear Wheel Cover
48	0601350648	Screw
49	0601350649	Bearing Housing
50	0601350650	Nut
51	0601350651	Rear Axle
52	0601350652	Flat Washer
53	0601350653	Rear Left Wheel
54	0601350654	Rear Left Wheel Cover
55	0601350655	Grass Bag Bracket
56	0601350656	Grass Bag
57	0601350657	Lever
58	0601350658	Cylindrical Pin
59	0601350659	Bolt
60	0601350660	Nut Bracket
61	0601350661	Hexagonal Nut
62	0601350662	Flat Washer
63	0601350663	Square Head Bolt
64	0601350664	Lower Handle Bar

65	0601350665	Knob	79	0601350679	Switch Cover
66	0601350666	Protective Hose	80	0601350680	Rubber Hose
67	0601350667	Cable Clamp	81	0601350681	Upper Handle Bar
68	0601350668	Terminal Sleeve	82	0601350682	Wire Trigger
69	0601350669	Switch Box	83	0601350683	Trigger Seat
70	0601350670	Elastic Sheet	84	0601350684	Reset Torsion Spring
71	0601350671	Button	85	0601350685	Trigger Cover
72	0601350672	Trigger Block	86	0601350686	Round Cover
73	0601350673	Rocket Switch	87	0601350687	Square Cover
74	0601350674	Power Cord	88	0601350688	Square Screw Cap
75	0601350675	Trigger	89	0601350689	Screw
76	0601350676	Switch Spring	90	0601350690	Protective Cover
77	0601350677	Cable Press Plate	91	0601350691	Press Plate
78	0601350678	Switch Cover	92	0601350692	Screw

If any parts are missing or damaged, or if you have any questions, please call the toll-free helpline at 1-800-689-9928.



This product is guaranteed for a period of **3 years from the date of original retail purchase** against defects in workmanship and materials, except for the following components:

- a) Component A: Batteries, chargers and carrying case, which are guaranteed for a period of 2 years from the date of original retail purchase against defects in workmanship and materials;
- b) Component B: Accessories, which are guaranteed for a period of 1 year from the date of original retail purchase against defects in workmanship and materials.

Subject to the conditions and limitations described below, this product, if returned to us with proof of purchase within the stated warranty period and if covered under this warranty, will be repaired or replaced (with the same model, or one of equal value or specification), at our option. We will bear the cost of any repair or replacement and any costs of labour relating thereto.

These warranties are subject to the following conditions and limitations:

- a) a bill of sale verifying the purchase and purchase date must be provided;
- b) this warranty will not apply to any product or part thereof which is worn or broken or which has become inoperative due to abuse, misuse, accidental damage, neglect or lack of proper installation, operation or maintenance (as outlined in the applicable owner's manual or operating instructions) or which is being used for industrial, professional, commercial or rental purposes;
- c) this warranty will not apply to normal wear and tear or to expendable parts or accessories that may be supplied with the product that are expected to become inoperative or unusable after a reasonable period of use;
- d) this warranty will not apply to routine maintenance and consumable items such as, but not limited to, fuel, lubricants, vacuum bags, blades, belts, sandpaper, bits, fluids, tune-ups or adjustments;
- e) this warranty will not apply where damage is caused by repairs made or attempted by others (i.e., persons not authorized by the manufacturer);
- f) this warranty will not apply to any product that was sold to the original purchaser as a reconditioned or refurbished product (unless otherwise specified in writing);
- g) this warranty will not apply to any product or part thereof if any part from another manufacturer is installed therein or any repairs or alterations have been made or attempted by unauthorized persons;
- h) this warranty will not apply to normal deterioration of the exterior finish, such as, but not limited

to, scratches, dents, paint chips, or to any corrosion or discolouring by heat, abrasive and chemical cleaners; and

- i) this warranty will not apply to component parts sold by and identified as the product of another company, which shall be covered under the product manufacturer's warranty, if any.

Additional Limitations

This warranty applies only to the original purchaser and may not be transferred. Neither the retailer nor the manufacturer shall be liable for any other expense, loss or damage, including, without limitation, any indirect, incidental, consequential or exemplary damages arising in connection with the sale, use or inability to use this product.

Notice to Consumer

This warranty gives you specific legal rights, and you may have other rights, which may vary from province to province. The provisions contained in this warranty are not intended to limit, modify, take away from, disclaim or exclude any statutory warranties set forth in any applicable provincial or federal legislation.

Made in China

Imported by

Mastercraft Canada Toronto, Canada M4S 2B8