

BLACK+DECKER

TM

INSTRUCTION MANUAL

MICROWAVE OVENS

Customer Care Line:

USA 1-800-842-1289

Accessories/Parts (USA)

1-800-842-1289



MODEL

○ AC028A2CA 1000W

PRECAUTIONS TO AVOID POSSIBLE EXPOSURE TO EXCESSIVE MICROWAVE ENERGY

- (a) Do not attempt to operate this oven with the door open since open door operation can result in harmful exposure to microwave energy.
It is important not to defeat or tamper with the safety interlocks.
- (b) Do not place any object between the oven front face and the door or allows soil or cleaner residue to accumulate on sealing surfaces.
- (c) Do not operate the oven if it is damaged. It is particularly important that the oven door close properly and that there is no damage to the:
 - (1) DOOR (bent)
 - (2) HINGES AND LATCHES (broken or loosened)
 - (3) DOOR SEALS AND SEALING SURFACES
- (d) The oven should not be adjusted or repaired by anyone except properly qualified service personnel.

Specifications

Model:	AC028A2CA
Rated Voltage:	120V~60Hz
Rated Input Power(Microwave):	1500W
Rated Output Power(Microwave):	1000W
Rated Input Power(Grill):	1150W
Rated Input Power(Convection):	1500W
Oven Capacity:	28 L
Turntable Diameter:	Ø315mm
External Dimensions:	520 x508x 326mm
Net Weight:	Approx.18.5kg

IMPORTANT SAFETY INSTRUCTIONS

When using electrical appliances basic safety precautions should be followed, including the following:

WARNING - To reduce the risk of burns, electric shock, fire, injury to persons or exposure to excessive microwave energy:

1. Read all instructions before using the appliance.
2. Read and follow the specific: "PRECAUTIONS TO AVOID POSSIBLE EXPOSURE TO EXCESSIVE MICROWAVE ENERGY" found on page 2.
3. This appliance must be grounded. Connect only to properly grounded outlet. See "GROUNDING INSTRUCTIONS" found on page 4.
4. Install or locate this appliance only in accordance with the provided installation instructions.
5. Some products such as whole eggs and sealed containers - for example, closed glass jars - are able to explode and should not be heated in this oven.
6. Use this appliance only for its intended use as described in the manual. Do not use corrosive chemicals or vapors in this appliance. This type of oven is specifically designed to heat, cook or dry food. It is not designed for industrial or laboratory use.
7. As with any appliance, close supervision is necessary when used by children.
8. Do not operate this appliance if it has a damaged cord or plug, if it is not working properly, or if it has been damaged or dropped.
9. This appliance should be serviced only by qualified service personnel. Contact nearest authorized service facility for examination, repair, or adjustment.
10. Do not cover or block any openings on the appliance.
11. Do not store this appliance outdoors. Do not use this product near water - for example, near a kitchen sink, in a wet basement, near a swimming pool, or similar location.
12. Do not immerse cord or plug in water.
13. Keep cord away from heated surface.
14. Do not let cord hang over edge of table or counter.
15. When cleaning surfaces of door and oven that comes together on closing the door, use only mild, nonabrasive soaps, or detergent applied with a sponge or soft cloth.
16. To reduce the risk of fire in the oven cavity:
 - 1). Do not overcook food. Carefully attend appliance when paper, plastic, or other combustible materials are placed inside the oven to facilitate cooking.
 - 2). Remove wire twist-ties from paper or plastic bag before placing bag in oven.
 - 3). If material inside of the oven ignite, keep oven door closed, turn oven off, and disconnect the power cord, or shut off power at the fuse or circuit breaker panel.
 - 4). Do not use the cavity for storage purposes. Do not leave paper products, cooking utensils, or food in the cavity when not in use.
17. Liquids, such as water, coffee, or tea are able to be overheated beyond the boiling point without appearing to be boiling. Visible bubbling or boiling when the container is removed from the microwave oven is not always present.

THIS COULD RESULT IN VERY HOT LIQUID SUDDENLY BOILING OVER WHEN THE CONTAINER IS DISTURBED OR A UTENSIL IS INSERTED INTO THE LIQUID.

To reduce the risk of injury to persons:

- 1) Do not overheat the liquid.
 - 2) Stir the liquid both before and halfway through heating it.
 - 3) Do not use straight-sided containers with narrow necks.
 - 4) After heating, allow the container to stand in the microwave oven for a short time before removing the container.
 - 5) Use extreme care when inserting a spoon or other utensil into the container.
18. Oversized food or oversized metal utensils should not be inserted in a microwave/toaster oven as they may create a fire or risk of electric shock.
 19. Do not clean with metal scouring pads. Pieces can burn off the pad and touch electrical parts involving a risk of electric shock.
 20. Do not use paper products when appliance is operated in the toaster mode.
 21. Do not store any materials, other than manufacturer's recommended accessories, in this oven when not in use.
 22. Do not cover racks or any other part of the oven with metal foil. This will cause overheating of the oven.

SAVE THESE INSTRUCTIONS

GROUNDING INSTRUCTIONS

This appliance must be grounded. In the event of an electrical short circuit, grounding reduces the risk of electric shock by providing an escape wire for the electric current. This appliance is equipped with a cord having a grounding wire with a grounding plug. The plug must be plugged into an outlet that is properly installed and grounded.

WARNING - Improper use of the grounding can result in a risk of electric shock.

Consult a qualified electrician or serviceman if the grounding instructions are not completely understood, or if doubt exists as to whether the appliance is properly grounded. If it is necessary to use an extension cord, use only a 3-wire extension cord that has a 3-blade grounded plug, and 3-slot receptacle that will accept the plug on the appliance. The marked rating of the extension cord shall be equal to or greater than the electrical rating of the appliance.

DANGER - Electric Shock Hazard

Touching some of the internal components can cause serious personal injury or death. Do not disassemble this appliance.

WARNING - Electric Shock Hazard

Improper use of the grounding can result in electric shock. Do not plug into an outlet until appliance is properly installed and grounded.

1. A short power-supply cord is provided to reduce the risks resulting from becoming entangled in or tripping over a longer cord.
2. Longer cord sets or extension cords are available and may be used if care is exercised in their use.
3. If a long cord or extension cord is used:
 - 1) The marked electrical rating of the cord set or extension cord should be at least as great as the electrical rating of the appliance.
 - 2) The extension cord must be a grounding-type 3-wire cord.
 - 3) The longer cord should be arranged so that it will not drape over the counter top or tabletop where it can be pulled on by children or tripped over unintentionally.

RADIO INTERFERENCE

1. Operation of the microwave oven may cause interference to your radio, TV or similar equipment.
2. When there is interference, it may be reduced or eliminated by taking the following measures:
 - 1) Clean door and sealing surface of the oven
 - 2) Reorient the receiving antenna of radio or television.
 - 3) Relocate the microwave oven with respect to the receiver.
 - 4) Move the microwave oven away from the receiver.
 - 5) Plug the microwave oven into a different outlet so that microwave oven and receiver are on different branch circuits.

UTENSILS

CAUTION - Personal Injury Hazard

Tightly-closed containers could explode. Closed containers should be opened and plastic pouches should be pierced before cooking.

See the instructions on "Materials you can use in microwave oven or to be avoided in microwave oven."

There may be certain non-metallic containers that are not safe to use for microwaving. If in doubt, you can test the utensil in question following the procedure below.

Utensil Test:

1. Fill a microwave-safe container with 1 cup of cold water (250ml) along with the utensil in question.
2. Cook on maximum power for 1 minute.
3. Carefully feel the container. If the empty container is warm, do not use it for microwave cooking.
4. Do not exceed 1 minute cooking time.

Materials you can use in microwave oven

Container	Remarks
Browning dish	Follow manufacturer* instructions. The bottom of browning dish must be at least 3/16 inch (5mm) above the turntable. Incorrect usage may cause the turntable to break.
Dinnerware	Microwave-safe only. Follow manufacturer's instructions. Do not use cracked or chipped dishes.
Glass jars	Always remove lid. Use only to heat food until just warm. Most glass jars are not heat resistant and may break.
Glassware	Heat-resistant oven glassware only. Make sure there is no metallic trim. Do not use cracked or chipped dishes.
Oven cooking bags	Follow manufacturer* instructions. Do not close with metal tie. Make slits to allow steam to escape.
Paper plates and cups	Use for short term cooking/warming only. Do not leave oven unattended while cooking.
Paper towels	Use to cover food for reheating and absorbing fat. Use with supervision for a short-term cooking only.
Parchment paper	Use as a cover to prevent splattering or a wrap for steaming.

Materials you can use in microwave oven

Material	Remarks
Plastic	Microwave-safe only. Follow the manufacturer* instructions. Should be labeled "Microwave Safe". Some plastic containers soften, as the food inside gets hot. "Boiling bags" and tightly closed plastic bags should be slit, pierced or vented as directed by package.
Plastic wrap	Microwave-safe only. Use to cover food during cooking to retain moisture. Do not allow plastic wrap to touch food.
Thermometers	Microwave-safe only (meat and candy thermometers).
Wax paper	Use as a cover to prevent splattering and retain moisture.

Materials to be AVOIDED in microwave oven

Item	Remarks
Aluminum tray	May cause arcing. Transfer food into microwave-safe dish.
Food carton with metal handle	May cause arcing. Transfer food into microwave-safe dish.
Metal or metal-trimmed utensils	Metal shields the food from microwave energy. Metal trim may cause arcing.
Metal twist ties	May cause arcing and could cause a fire in the oven.
Paper bags	May cause a fire in the oven.
Plastic foam	Plastic foam may melt or contaminate the liquid inside when exposed to high temperature.
Wood	Wood will dry out when used in the microwave oven and may split or crack.

SETTING UP YOUR OVEN

Names of Oven Parts and Accessories

Remove the oven and all materials from the carton and oven cavity.

Your oven comes with the following accessories:

Glass tray	1
Turntable ring assembly	1
Instruction Manual	1

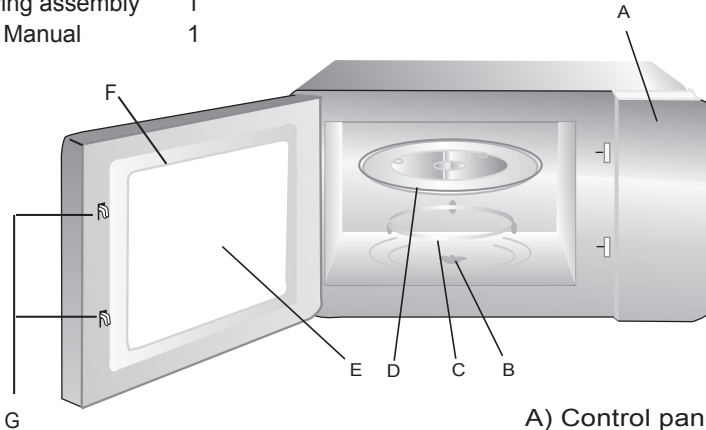

- A) Control panel
- B) Turntable shaft
- C) Turntable ring assembly
- D) Glass tray
- E) Observation window
- F) Door assembly
- G) Safety interlock system



Grill tray(Cannot be used in microwave function and must be placed on the grill rack)



Grill Rack(Cannot be used in microwave function and must be placed on the glass tray)

Turntable Installation

Hub (underside)

Glass tray

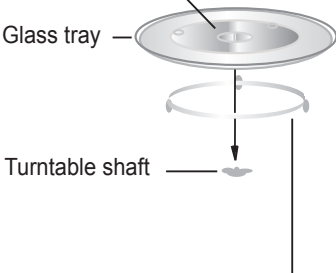

Turntable shaft

Turntable ring assembly

- a. Never place the glass tray upside down. The glass tray should never be restricted.
- b. Both glass tray and turntable ring assembly must always be used during cooking.
- c. All food and containers of food are always placed on the glass tray for cooking.
- d. If glass tray or turntable ring assembly cracks or breaks, contact your nearest authorized service center.

Countertop Installation

Remove all packing material and accessories. Examine the oven for any damage such as dents or broken door. Do not install if oven is damaged.

Cabinet: Remove any protective film found on the microwave oven cabinet surface. Do not remove the light brown Mica cover that is attached to the oven cavity to protect the magnetron.

Installation

1. Select a level surface that provide enough open space for the intake and/or outlet vents.

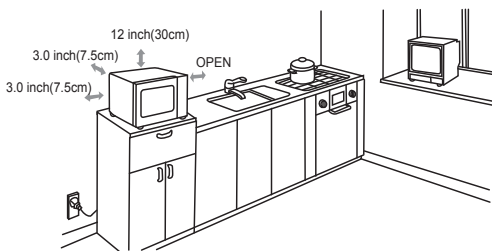

A minimum clearance of 3.0 inches (7.5cm) is required between the oven and any adjacent walls. One side must be open.

- (1) Leave a minimum clearance of 12 inches (30cm) above the oven.
- (2) Do not remove the legs from the bottom of the oven.

- (3) Blocking the intake and/or outlet openings can damage the oven.
 - (4) Place the oven as far away from radios and TV as possible. Operation of microwave oven may cause interference to your radio or TV reception.
2. Plug your oven into a standard household outlet. Be sure the voltage and the frequency is the same as the voltage and the frequency on the rating label.

WARNING: Do not install oven over a range cooktop or other heat-producing appliance. If installed near or over a heat source, the oven could be damaged and the warranty would be void.

The accessible surface may be hot during operation.





OPERATION

This microwave oven uses modern electronic control to adjust cooking parameters to meet your needs better for cooking.

1. Clock Setting

When the microwave oven is electrified, the oven will display "0:00", buzzer will ring once.

- 1) Press " **TIMER/ CLOCK** " twice, the hour figures will flash.
- 2) Turn "  " to adjust the hour figures, the input time should be within 1--12(12-hour).
- 3) Press " **TIMER/ CLOCK** ", the minute figures will flash.
- 4) Turn "  " to adjust the minute figures, the input time should be within 0--59.
- 5) Press " **TIMER/ CLOCK** " to finish clock setting. ":" will flash.

Note: 1) If the clock is not set, it will not function when powered.

- 2) During the process of clock setting, if you press " **STOP/CANCEL** ", the oven will go back to the previous status automatically.

2. Kitchen Timer



- 1) Press " **TIMER/ CLOCK** " once, the screen will display "00:00".
- 2) Turn "  " to enter the correct timer. (The maximum cooking time is 95 minutes.)
- 3) Press " **START/+30SEC.** " to confirm setting.
- 4) When the kitchen time is reached, the buzzer will ring 5 times.

If the clock be set(12-hour system), the screen will display the current time.

Note: (1) The kitchen time is different from 12-hour system, Kitchen Timer is a timer.

- (2) During the kitchen timer, any program cannot be set.

3. Microwave Cooking

- 1) Press the " **MICRO./GRILL/CONVEC./COMBO** " once and "PL10" will flash.
- 2) Press " **START/+30SEC.** " to confirm. The "PL10" will light.
- 3) Press " **MICRO./GRILL/CONVEC./COMBO**" repeatedly or turn "  " to select the microwave power from 100% to 10%. "PL10", "PL9", "PL8", "PL7", "PL6", "PL5", "PL4", "PL3", "PL2", "PL1" will display in order.
- 4) Press " **START/+30SEC.** " to confirm.
- 5) Turn "  " to adjust the cooking time. (The time setting should be 0:05- 95:00.)
- 6) Press " **START/+30SEC.** " to start cooking.



NOTE: the step quantities for the adjustment time of the coding switch are as follow:

- 0---1 min : 5 seconds
- 1---5 min : 10 seconds
- 5---10 min : 30 seconds
- 10---30 min : 1 minute
- 30---95 min : 5 minutes

Microwave Power Chart



Level	10	9	8	7	6	5	4	3	2	1
Power	100%	90%	80%	70%	60%	50%	40%	30%	20%	10%
Display	PL10	PL9	PL8	PL7	PL6	PL5	PL4	PL3	PL2	PL1

4. Grill Cooking

- 1) Press the "MICRO./GRILL/CONVEC./COMBO" once and "PL10" will flash.
- 2) Press "MICRO./GRILL/CONVEC./COMBO" repeatedly or turn "  " to select the grill function. Stop pressing/turning when "G-1" flash.
- 3) Press " **START/+30SEC.** " to confirm. The "G-1" will light.
- 4) Turn "  " to adjust the cooking time. (The time setting should be 0:05- 95:00.)
- 5) Press " **START/+30SEC.** " to start cooking.

Note: If half the grill time passes, the oven sounds twice, and this is normal. In order to have a better effect of grilling food, you should turn the food over, close the door, and then press " **START/+30SEC.** " to continue cooking. If no operation, the oven will continue working.

5. Combination Cooking



- 1) Press the "MICRO./GRILL/CONVEC./COMBO" once and "PL10" will display.
- 2) Press "MICRO./GRILL/CONVEC./COMBO" repeatedly or turn "  " to select combination mode. Stop pressing/turning when "G-2", "G-3", "C-1" display.
- 3) Press " **START/+30SEC.** " to confirm.
- 4) Turn "  " to adjust the cooking time. (The time setting should be 0:05- 95:00.)
- 5) Press " **START/+30SEC.** " to start cooking.

Note: Combination instructions



Function	Display	Microwave	Grill	Convection
Combi.1	G-2	●	●	
Combi.2	G-3	●	●	
Combi.3	C-1	●		●

6. Convection Cooking(With preheating function)

The convection cooking can let you to cook the food as a traditional oven. Microwave is not used. It is recommended that you should preheat the oven to the appropriate temperature before placing the food in the oven.

- 1) Press the "MICRO./GRILL/CONVEC./COMBO" once and "PL10" will flash.
- 2) Press "MICRO./GRILL/CONVEC./COMBO" repeatedly or turn "  " to select convection function. Stop pressing/turning when "100" flash.
- 3) Press " **START/+30SEC.** " to confirm.
- 4) Turn "  " to select the convection temperature.
Note:the temperature can be chosen from 100 °F to 425 °F
- 5) Press the " **START/+30SEC.** " to confirm the temperature.
- 6) Press the " **START/+30SEC.** " to start preheating.When the preheating temperature arrives, the buzzer will sound twice to remind you to put the food into the oven. And the preheated temperature is displayed and flash.
- 7) Put the food into the oven and close the door.
Turn "  " to adjust the cooking time. (The maximum setting time is 95 minutes.)
- 8) Press the " **START/+30SEC.** " key to start cooking.

7. Convection Cooking(Without pre-heating function)



- 1) Press the "MICRO./GRILL/CONVEC./COMBO" once and "PL10" will flash.
- 2) Press "MICRO./GRILL/CONVEC./COMBO" repeatedly or turn "  " to select convection function. Stop pressing/turning when "100" flash.
- 3) Press " **START/+30SEC.** " to confirm.
- 4) Turn "  " to select the convection temperature.
Note:the temperature can be chosen from 100 °F to 425 °F
- 5) Press the " **START/+30SEC.** " to confirm the temperature.
- 6) Turn "  " to adjust the cooking time. (The maximum setting time is 95 minutes.)
- 7) Press the " **START/+30SEC.** " key to start cooking.

8. Multi-Stage Cooking

Up to 2 stages of cooking can be set. If one stage is defrosting, defrosting is automatically placed in the first stage. After the cooking at each stage, the buzzer will sound and start the next cooking. At the end of the first stage of cooking, the buzzer sounds 1 time to start the second stage of cooking. The cooking settings for each stage are the same as the single stage.)

Note: Auto menu and preheating cannot be set as one of the multi-stage.

Example: if you want to defrost the food for 5 minutes, then to cook with 80% microwave power for 7 minutes. The steps are as following:



- 1) Press "**WEIGHT/TIME DEFROST**" twice, the screen will display "d EF2";
- 2) Turn " " to adjust the defrost time of 5 minutes;
- 3) Press "**MICRO./GRILL/CONVEC./COMBO**" once and "PL10" will flash;
- 4) Press "**START/+30SEC.**" to confirm;
- 5) Turn " " to choose 80% microwave power till "PL8" display;
- 6) Press "**START/+30SEC.**" to confirm;
- 7) Turn " " to adjust the cooking time of 7 minutes;
- 8) Press "**START/+30SEC.**" to start cooking.

9. Speedy Cooking

- 1) In waiting state, press "**START/+30SEC.**" key to cook with 100% power level for 30 seconds. Each press on the same key can increase 30 seconds. The maximum cooking time is 95 minutes.
- 2) During microwave, grill, convection and combination states, press "**START/+30SEC.**" key to increase 30 seconds' cooking time.

Note: this function cannot work under weight defrost, auto menu cooking or low temp control.

10. Auto Menu

- 1) In waiting state, turn " " right to choose the function wanted, and "A1", "A2", "A3"... "A12" will be displayed. More menu options on the next page.
- 2) Press "**START/+30SEC.**" to confirm the menu you need.
- 3) Turn " " to choose the weight of menu, and "Oz" indicator will light.
- 4) Press "**START/+30SEC.**" to start cooking.

Note: 1) Cake menu is under convection cooking with 300°F -warm-up function, and you should preheat first following the auto menu operation, when the oven reaches the temperature, it will stop cooking and sound to remind opening the door to put cake in, then press "**START/+30SEC.**" to start cooking.

2) When roast chicken is selected and 2/3 of the time has passed, it will ring twice to tell you to turn over the food. You can just leave it continue. For better result, turn the food over, close the door, and then press "**START/+30SEC.**" to continue cooking.

Menu	Weight	Display	Power
A1 POPCORN	2.75 Oz	2.75 Oz	100%
	3.2 Oz	3.2 Oz	
	3.5 Oz	3.5 Oz	
A2 AUTO REHEAT	5 Oz	5 Oz	100%
	8 Oz	8 Oz	
	12 Oz	12 Oz	
	15 Oz	15 Oz	
	21 Oz	21 Oz	
A3 POTATO	8 Oz	1	100%
	16 Oz	2	
	24 Oz	3	
A4 MEAT	4 Oz	4 Oz	100%
	8 Oz	8 Oz	
	16 Oz	16 Oz	
	22 Oz	22 Oz	
A5 Fresh VEGETABLE	4 Oz	4 Oz	100%
	8 Oz	8 Oz	
	16 Oz	16 Oz	
A6 Frozen Vegetable	4 Oz	4 Oz	100%
	8 Oz	8 Oz	
	16 Oz	16 Oz	
A7 FISH	4 Oz	4 Oz	80%
	8 Oz	8 Oz	
	12 Oz	12 Oz	
	16 Oz	16 Oz	
	22 Oz	22 Oz	
A8 PASTA	1.75 Oz(with 16Oz cold water)	1.75 Oz	80%
	3.5 Oz(with 28Oz cold water)	3.5 Oz	
	5.5 Oz(with 42Oz cold water)	5.5 Oz	
A9 Beverage	1 cup	1	100%
	2 cup	2	
	3 cup	3	
A10 CAKE	16 Oz	16 Oz	Please do not put the cake into the oven at the beginning. The oven needs to be preheated to 300 °F first. After several minutes, the buzzer beeps twice to remind you to put the cake into the oven. After putting the cake in the oven, please press start again. The timer will count down, and the cake will be cooked perfectly.
A11 PIZZA	10 Oz	10 Oz	100% microwave power + 400°F convection power
	14 Oz	14 Oz	
A12 Roast Chicken	16 Oz	16 Oz	100% microwave power + 400°F convection power During the cooking process, the oven beep twice to remind you to turn the food over.
	24 Oz	24 Oz	
	32 Oz	32 Oz	
	40 Oz	40 Oz	
	48 Oz	48 Oz	

11. Defrost by W.T.

- 1) Press "WEIGHT/TIME DEFROST" key once, the oven will display "dEF1",.
- 2) Turn "  " to select the weight of food. At the same time, "Oz" will light, The weight should be 4-100 Oz.
- 3) Press "START/+30SEC." key to start defrosting.

12. Defrost by Time



- 1) Press " WEIGHT/TIME DEFROST " key twice, the oven will display "dEF2".
- 2) Turn "  " to select the cooking time. The maximum setting time is 95 minutes.
- 3) Press " START/+30SEC. " key to start defrosting.

13. Air Fry

- 1) Press the " AIR FRY " key once, "H1" will flash.
- 2) Turn "  " to choose the menu from H1 to H9. And "H1", "H2", "H3"... "H9" will display.
- 3) Press " START/+30SEC." to start cooking.

No.	Menu	Power
H1	Frozen French fries	425°F without preheat
H2	Frozen Potato croquettes	425°F without preheat
H3	Frozen Calamari	425°F without preheat
H4	Frozen Onion rings	425°F without preheat
H5	Frozen Chicken nuggets	425°F without preheat
H6	Steak	425°F without preheat
H7	Shrimps	425°F without preheat
H8	Vegetable	425°F without preheat
H9	Chicken wings	425°F without preheat



14. Crispy Grill

- 1) Press the "CRISPY BROWN" key, the screen will display "C1".
- 2) Press "CRISPY BROWN" repeatedly or turn "  " to select grill mode.
Stop prssing/turning when "C1", "C2", "C3" or "C4" displays.
- 3) Press "START/+30SEC." to confirm.
- 4)Turn "  " to select the cooking weight.
- 5) Press "START/+30SEC." to start cooking.

Note: All the food should be placed on the grill tray, and the grill tray must be placed on the grill rack.

Crispy grill	Weight	Power
C1 Cordon bleu (fresh mini pizza)	7.00 Oz	15% microwave power + 85% grill power
	10.5 Oz	
	14.00 Oz	
	18.00 Oz	
	21.00 Oz	
C2(lasagna)	7.00 Oz	15% microwave power + 85% grill power
	10.5 Oz	
	14.00 Oz	
	18.00 Oz	
	21.00 Oz	
C3(bread)	3.50 Oz	15% microwave power + 85% grill power
	7.00 Oz	
	10.5 Oz	
C4(pie/tart)	7.00 Oz	425°F with preheat
	10.5 Oz	
	14.00 Oz	
	18.00 Oz	

15. Low Temp Control

- 1) Press the " **LOW TEMP. CONTROL** " key , the screen will display "L1".
- 2) Press the " **LOW TEMP. CONTROL** " repeatedly or turn "  " to select cooking mode .
"L1", "L2", "L3", "L4" or "L5" will flash.
- 3) Press " **START/+30SEC.** " to confirm.
- 4) Turn "  " to select the cooking temperature.
- 5) Press " **START/+30SEC.** " to confirm.
- 6) Turn "  " to adjust the cooking time.
- 7) Press " **START/+30SEC.** " to start cooking.

Display	105°F	120°F	140°F	160°F	175°F	195°F	210°F	230°F	Cooking time (Max)
L1(Slow cook)						✓		✓	12h
L2(Keep warm)			✓	✓	✓				95min
L3(Food dry)	✓	✓	✓	✓	✓	✓			12h
L4(Yogurt/ferment)	✓								12h
L5(Warming box)	✓	✓	✓	✓	✓	✓	✓		95min

16. Deodorization

Press the " **DEODORIZATION** " key to start deodorizing .

17. Speedy Microwave Cooking

In waiting state, turn "  " left to choose cooking time directly then press " **START/+30SEC.** " key to cook with 100% microwave power. This program can be set as the first stage of multi-stage cook.

18. Lock-out Function for Children

Lock: In waiting state, press " **STOP/CANCEL** " for 3 seconds, there will be a long "beep" denoting entering into the children-lock state and the lock indicator will light. Screen will display current time or 0:00.

Lock quitting: In locked state, press " **STOP/CANCEL** " for 3 seconds, there will be a long "beep" denoting that the lock is released, and the lock indicator will disappear.

19. Specification

- 1) The buzzer will sound once when turning the knob at the beginning;
- 2) "**START/+30SEC.**" must be pressed to continue cooking if the door is opened during cooking;
- 3) Once the cooking program has been set ,if "**START/+30SEC.**" is not pressed within 5 minutes the current time will be displayed and the program cancelled.
- 4) The buzzer sounds once by efficient press, inefficient press will be no response.
- 5) The buzzer will sound five times to remind you when cooking is finished.

20. Inquiring Function

- 1) During cooking state, press "**TIMER/ CLOCK**" to check the current time. The time will be displayed for 3 seconds.
- 2) In cooking state, press "**MICRO./GRILL/CONVEC./COMBO**" the current power will be displayed for 3 seconds.

21. Mute Function

Enter mute function:

In waiting state, press "**STOP/CANCEL**" and hold, then press "**START/+30SEC.**" within 3 seconds, the buzzer will sound once and the oven will enter mute mode. Any operation cannot make the buzzer sound.

Exit mute function:

In waiting state, press "**STOP/CANCEL**" and hold, then press "**START/+30SEC.**" within 3 seconds, the buzzer will sound once and the oven will exit mute mode.

22. ECO Function

Enter ECO mode: In waiting state, press "**STOP/CANCEL**" briefly, the screen will be off.

Exit ECO mode: Press any key.

MAINTENANCE

Troubleshooting

Check your problem by using the chart below and try the solutions for each problem. If the microwave oven still does not work properly, contact the nearest authorized service center.

TROUBLE	POSSIBLE CAUSE	POSSIBLE REMEDY
Oven will not start	<ul style="list-style-type: none">a. Electrical cord for oven is not plugged in.b. Door is open.c. Wrong operation is set.	<ul style="list-style-type: none">a. Plug into the outlet.b. Close the door and try again.c. Check instructions.
Arcing or sparking	<ul style="list-style-type: none">a. Materials to be avoided in microwave oven were used.b. The oven is operated when empty.c. Spilled food remains in the cavity.	<ul style="list-style-type: none">a. Use microwave-safe cookware only.b. Do not operate with oven empty.c. Clean cavity with wet towel.
Unevenly cooked foods	<ul style="list-style-type: none">a. Materials to be avoided in microwave oven were used.b. Food is not defrosted completely.c. Cooking time, power level is not suitable.d. Food is not turned or stirred.	<ul style="list-style-type: none">a. Use microwave-safe cookware only.b. Completely defrost food.c. Use correct cooking time, power level.d. Turn or stir food.
Overcooked foods	Cooking time, power level is not suitable.	Use correct cooking time, power level.
Undercooked foods	<ul style="list-style-type: none">a. Materials to be avoided in microwave oven were used.b. Food is not defrosted completely.c. Oven ventilation ports are restricted.d. Cooking time, power level is not suitable.	<ul style="list-style-type: none">a. Use microwave-safe cookware only.b. Completely defrost food.c. Check to see that oven ventilation ports are not restricted.d. Use correct cooking time, power level.
Improper defrosting	<ul style="list-style-type: none">a. Materials to be avoided in microwave oven were used.b. Cooking time, power level is not suitable.c. Food is not turned or stirred.	<ul style="list-style-type: none">a. Use microwave-safe cookware only.b. Use correct cooking time, power level.c. Turn or stir food.