

FEATURES AND BENEFITS

PERFECT FIT WIPER TRANSMISSION LINKAGE



JANUARY 31, 2022

FEATURES & BENEFITS

- OE SPECIFICATION DESIGN
- OVER 850 SKUS PROVIDING COMPLETE COVERAGE FOR THOUSANDS OF APPLICATIONS
- STEEL DESIGN EXTENDS THE STRENGTH OF THE WIPER LINKAGE
- WELDED SHAFT DESIGN FOR SEVERE NORTH AMERICAN WEATHER
- POM DUPONT PLASTIC BUSHINGS FOR A ROBUST WIPER LINKAGE
- PREMIUM QUALITY BEARING FOR A LONG-LASTING WIPER LINKAGE
- GALVANIZED & COATED COMPONENTS FOR ANTI-RUST & ANTI-JAMS
- PRE-GREASED FOR DURABILITY & EASY INSTALLATION
- COMPLETE WIPER TRANSMISSION LINKAGE ASSEMBLY WITH CRANK ARM FOR QUICK AND EASY INSTALLATION
- UPARTS GROUP NORTH AMERICAN ENGINEERING WORKS TO CONTINUOUSLY IMPROVE ORIGINAL EQUIPMENT DESIGNS
- BUILT TO STRICT QUALITY CONTROL STANDARDS
- SAVES TIME & MONEY BY REPLACING COMPLETE UNIT
- PRODUCTS ARE TESTED BY A CERTIFIED LABORATORY
- BACKED WITH A FULL TWO (2) YEAR WARRANTY

WIPER TRANSMISSION LINKAGE ASSEMBLY SPECIALIST

OE SPECIFICATION DESIGN

OEM EXACT MEASUREMENT DESIGN TO ENSURE THE PERFECT FIT OF THE
WIPER TRANSMISSION LINKAGE ASSEMBLY



WIPER TRANSMISSION LINKAGE ASSEMBLY SPECIALIST

COMPLETE LINE OF WIPER TRANSMISSION LINKAGE ASSEMBLY

INDUSTRY-LEADING WITH OVER 850 SKUS

PROVIDING COMPLETE COVERAGE FOR THOUSANDS OF APPLICATIONS



WIPER TRANSMISSION LINKAGE ASSEMBLY SPECIALIST

STEEL DESIGN EXTENDING THE STRENGTH OF THE LINKAGE

ROBUST & HEAVY STEEL LINKAGE DESIGN INSTEAD OF OEM PLASTIC OR ALUMINIUM DESIGN TO REINFORCE THE WIPER LINKAGE ASSEMBLY

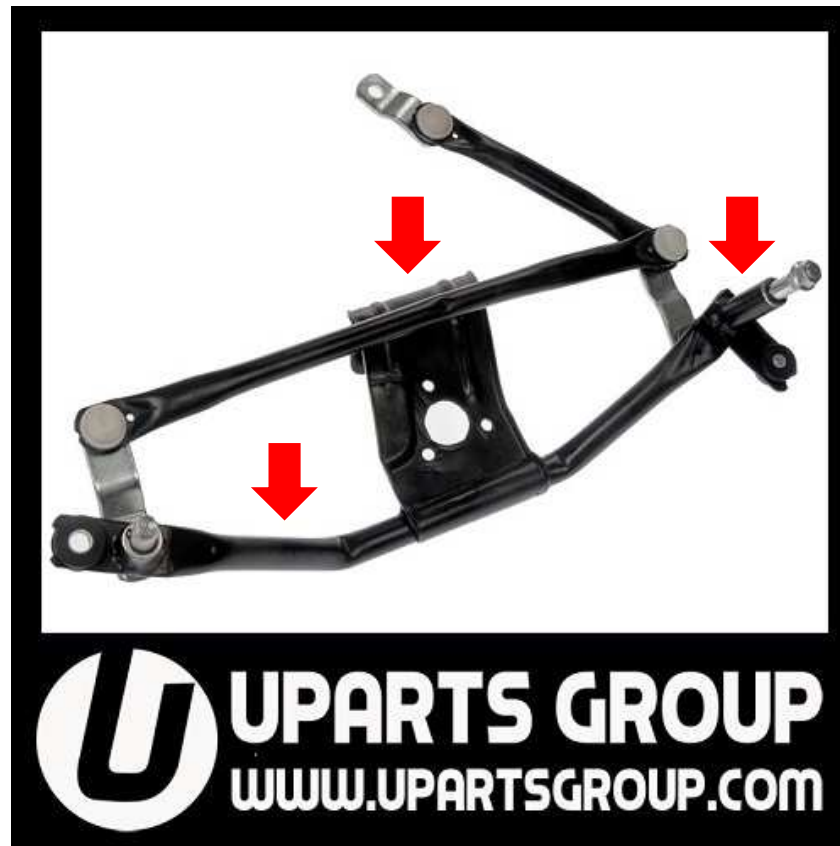

WELDED SHAFT DESIGN FOR SEVERE WEATHER

PERFECT FIT WIPER LINKAGE SHAFTS ARE WELDED TO FORTIFY THE STRENGTH OF THE SHAFTS FOR SEVERE NORTH AMERICAN WEATHER

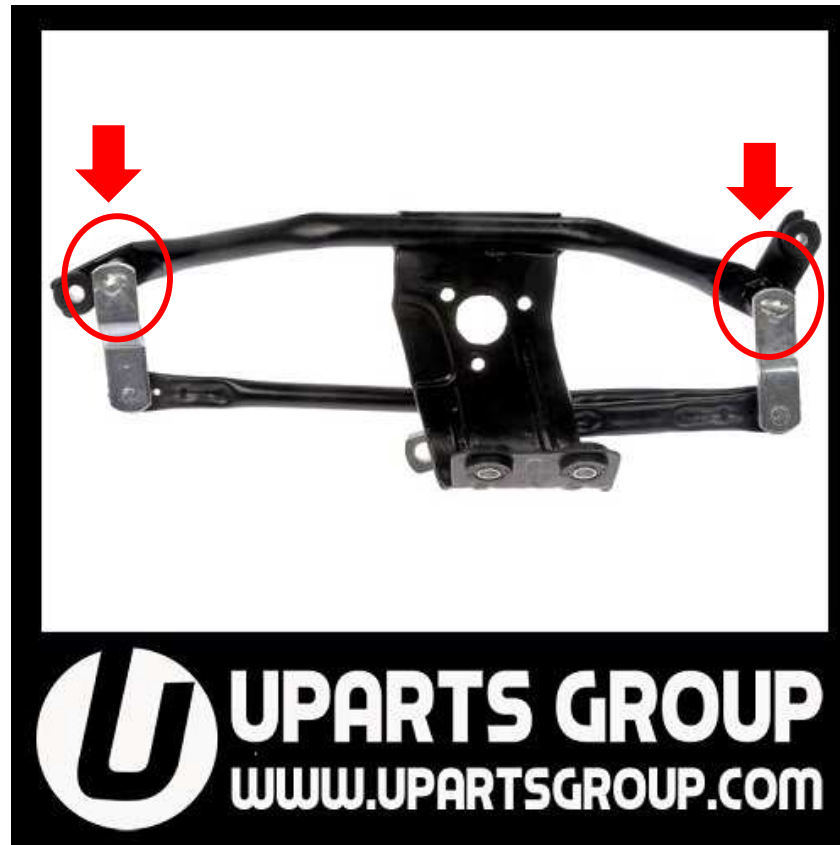

WIPER TRANSMISSION LINKAGE ASSEMBLY SPECIALIST

POM DUPONT PLASTIC BUSHINGS FOR A ROBUST WIPER LINKAGE

PREMIUM QUALITY POM DUPONT PLASTIC BUSHINGS DESIGNED TO EXCEED
& ENSURE THE ROBUSTNESS OF THE PERFECT FIT WIPER LINKAGE

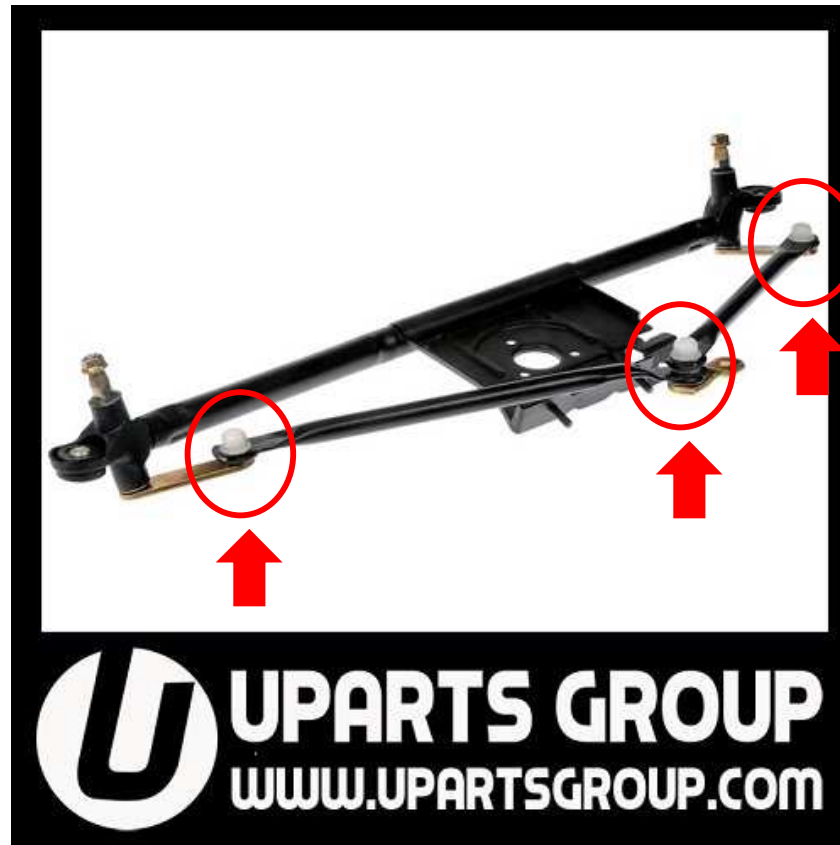

WIPER TRANSMISSION LINKAGE ASSEMBLY SPECIALIST

PREMIUM QUALITY BEARING FOR A LONG-LASTING WIPER LINKAGE

PREMIUM QUALITY BEARINGS FOR SMOOTH PIVOTING
AND A LONG-LASTING WIPER LINKAGE ASSEMBLY



WIPER TRANSMISSION LINKAGE ASSEMBLY SPECIALIST

GALVANIZED & COATED COMPONENTS FOR ANTI-RUST

PERFECT FIT WIPER LINKAGE COMPONENTS ARE GALVANIZED AND COATED TO PROVIDE THE LINKAGE ASSEMBLY WITH EXTRA PROTECTION AGAINST RUST AND COMPONENT JAMS

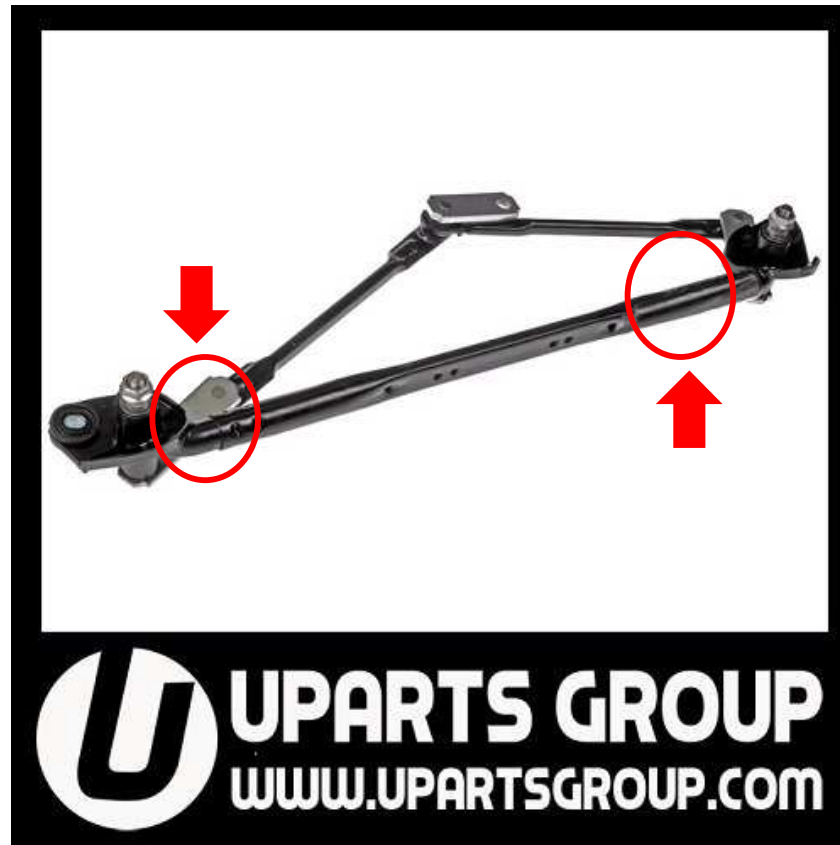

WIPER TRANSMISSION LINKAGE ASSEMBLY SPECIALIST

PRE-GREASED FOR DURABILITY & EASY INSTALLATION

PERFECT FIT WIPER LINKAGE PIVOTS, SHAFTS AND BUSHINGS ARE PRE-GREASED TO EXTEND THE DURABILITY OF THE WIPER TRANSMISSION LINKAGE ASSEMBLY AND FOR EASY INSTALLATION

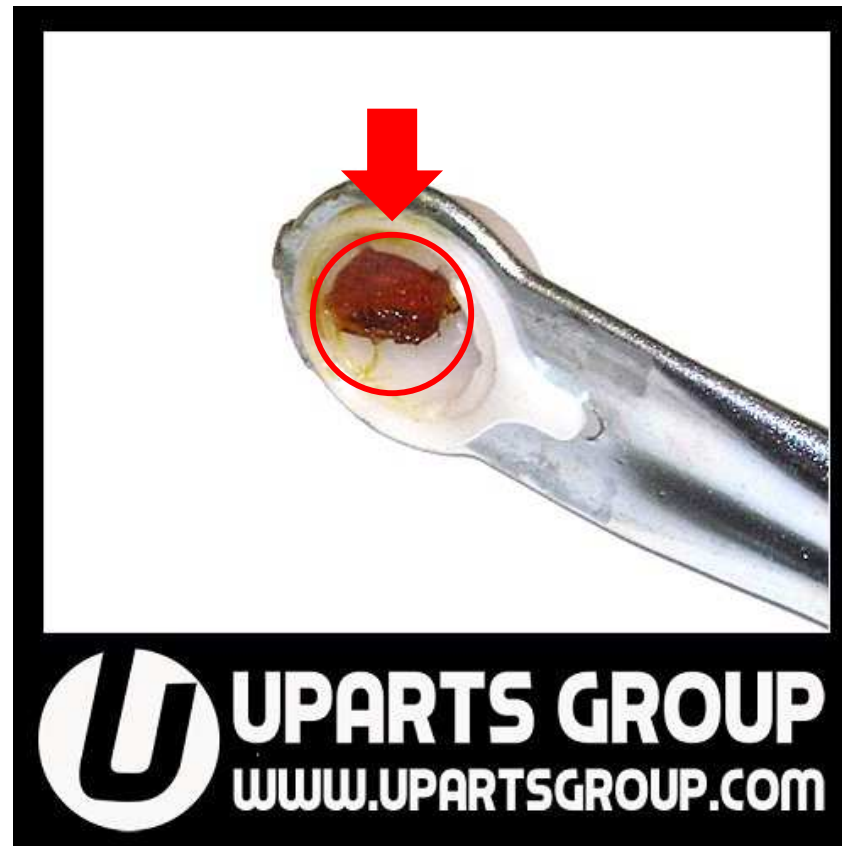

COMPLETE WIPER LINKAGE ASSEMBLY WITH CRANK ARM

COMPLETE WIPER TRANSMISSION LINKAGE ASSEMBLY WITH CRANK ARM
FOR QUICK AND EASY INSTALLATION.



WIPER TRANSMISSION LINKAGE ASSEMBLY SPECIALIST

IMPROVING ORIGINAL EQUIPMENT DESIGNS

IMPROVEMENT OF ORIGINAL EQUIPMENT DESIGNS BY THE EXPERIENCED & DYNAMIC ENGINEERING TEAM OF UPARTS GROUP NORTH AMERICA

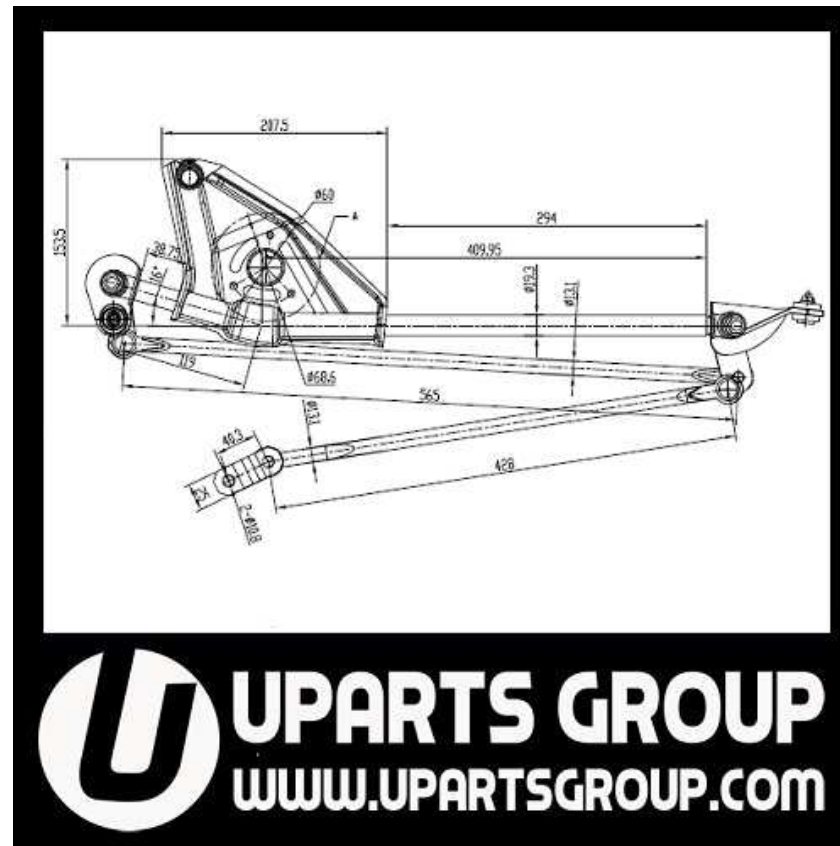

WIPER TRANSMISSION LINKAGE ASSEMBLY SPECIALIST

BUILT TO STRICT QUALITY CONTROL STANDARDS

OUR WIPER TRANSMISSION LINKAGE ASSEMBLY IS BUILT UNDER CONTROLLED CONDITIONS AND MEETS STRICT QUALITY CONTROL REQUIREMENTS BEFORE BEING RELEASED FROM OUR FACTORY



SAVES TIME & MONEY BY REPLACING COMPLETE UNIT

PERFECT FIT WIPER TRANSMISSION LINKAGE ASSEMBLY IS
A DIRECT FIT AND BOLTS IN FOR A QUICK DIY INSTALLATION
– SAVING YOU BOTH TIME & MONEY!



The graphic features three numbered speech bubbles (1, 2, 3) at the top, followed by the text "Easy Install". Below this is a blue box containing a clock icon and a stack of money icon. A purple banner at the bottom of the blue box reads "Save Time & Money". At the bottom of the entire graphic is the UPARTS GROUP logo and website address.

Easy Install

Save Time & Money

 **UPARTS GROUP**
WWW.UPARTSGROUP.COM

PRODUCTS ARE TESTED BY A CERTIFIED LABORATORY
DESIGN, PROTOTYPE AND PRODUCT ARE CERTIFIED BY ACTUAL VEHICLE
TRY-ONS AND TESTS THAT FOLLOW STRICT STANDARDS



WIPER TRANSMISSION LINKAGE ASSEMBLY SPECIALIST

BACKED WITH A FULL TWO (2) YEAR WARRANTY

PERFECT FIT WIPER TRANSMISSION LINKAGE ASSEMBLY IS FULLY BACKED
WITH A FULL TWO (2) YEAR WARRANTY



WIPER TRANSMISSION LINKAGE ASSEMBLY SPECIALIST

UPARTS GROUP

8509 9TH AVENUE
MONTREAL, QUEBEC H1Z 2Z6
CANADA

TOLL-FREE: 1.877.376.8998

TELEPHONE: 1.514.376.8998

FAX: 1.514.376.6720

EMAIL: INFO@UPARTSGROUP.COM

WEB: WWW.UPARTSGROUP.COM